

# HEAR

# THE

# MUSIC.

## EXPERIENCE THE USA

NEW ORLEANS, LOUISIANA



[VisitTheUSA.com](http://VisitTheUSA.com)



[VisitTheUSA.com/Music](http://VisitTheUSA.com/Music)

● Big test for a cult retailer 16

● Will farmers stick with Trump? 30

● The lure of long-lost gold 54

# Bloomberg Businessweek

April 15, 2019 ● EUROPE EDITION

## Germany's Fragile Future

### Special Report

Europe's most  
important  
economy is  
sagging

The country's  
biggest bank  
needs help

And the world  
will soon lose one  
of its strongest  
leaders

**YOU STOPPED SMOKING  
NOW START SCREENING**



**EVA-MARIE**

QUIT AFTER SMOKING 12,000  
PACKS OF CIGARETTES  
OVER 15 YEARS



Now there's a new screening that can catch lung cancer early and could save lives.

Talk to your doctor or learn more at  
[SavedByTheScan.org](http://SavedByTheScan.org)



# FUTURE IS LIVE TAKE YOUR BUSINESS TO THE NEXT LEVEL

16-18  
MAY  
PARIS

**100.000 attendees** from all over the world  
**9.000 startups** to meet with

# VIVA TECHNOLOGY

**30% off with the discount code : BWRVT19\***

\* On «late» price passes - offer ends May 15 2019

ORGANIZERS



Groupe Les Echos

PLATINUM PARTNERS



Google



LVMH



Bloomberg



euronews.

africanews.



TC TechCrunch

THE WALL STREET JOURNAL.  
Read ambitiously





◀ Johnny Portorreal has led thousands of Dominicans in pursuit of a long-lost inheritance

**FEATURES**

- 44 **Special Report: Germany's Uncertain Future**  
Deutsche Bank is big. Should it get bigger?
- 46 The *Wirtschaftswunder* might not be ready for electric vehicles
- 50 Angela's legacy may be in Annegret's hands
- 52
- 54 **The Hunt for Jacinto's Gold**  
For generations, the descendants of Jacinto del Rosario have believed an untold fortune belongs to them. But does it even exist?

■ IN BRIEF	7	Uber's IPO; Erdogan's do-over; a black hole's first portrait
■ AGENDA	8	Banks report earnings; Indonesia votes; Coachella rocks
■ OPINION	8	In Nigeria, Baba Go Slow better get to work fast
<hr/>		
■ REMARKS	12	Brexit, according to King Alfred the Great
<hr/>		
<b>1</b> BUSINESS	16	Wegmans brings its grocery magic to New York City
	18	Fiat's tiny cars prove a tough sell in the land of the SUV
<hr/>		
<b>2</b> TECHNOLOGY	20	Ola's co-founder tells SoftBank to back off
	22	It took three hours to ID our reporter from her DNA
<hr/>		
<b>3</b> FINANCE	25	Big Oil follows the money—to fight climate change
	27	Wall Street's newest high-risk investment? English majors
<hr/>		
<b>4</b> ECONOMICS	30	▼ A visit to the pig farms and apple orchards on the front lines of Trump's trade war



How to Contact  
*Bloomberg Businessweek*

Editorial  
212 617-8120  
Ad Sales  
212 617-2900  
731 Lexington Ave.,  
New York, NY 10022  
Email  
bwreader  
@bloomberg.net  
Fax  
212 617-9065  
Subscription Customer  
Service URL  
businessweekmag  
.com/service  
Reprints/Permissions  
800 290-5460 x100  
or email  
businessweekreprints  
@theygsgroup.com

Letters to the Editor can be sent by email, fax, or regular mail. They should include the sender's address, phone number(s), and email address if available. Connections with the subject of the letter should be disclosed. We reserve the right to edit for sense, style, and space.

Follow us on social media

Facebook  
facebook.com/  
bloomberg  
businessweek/  
Twitter  
@BW  
Instagram  
@businessweek

<b>5</b> POLITICS	36	A terrific Tax Day for a very special CEO
	38	Democracy isn't dead, but it may need a tuneup
<hr/>		
<b>+</b> SOLUTIONS	41	Employers prepare for the exodus of boomer brains
	42	Retirement saving is easier once the kids are gone
<hr/>		
■ PURSUITS	67	Ditch your noisy pub for a high-fidelity cocktail bar
	70	Is there any science behind essential oils?
	71	Bugs you'll want to find in your salad
	72	Armchairs for those who think big
	74	The sordid battle for sex.com
	75	A pollution monitor, the air-testing accessory
<hr/>		
■ LAST THING	76	Don't tell the nationalists, but global migration is declining



Cover:  
Photo illustration by  
731; photos: car: BMW;  
Merkel: Getty Images;  
building: Bloomberg

Anything is possible when  
she follows her dreams.

But it all starts with a classroom.

A space that says

**she is the exception.**

She is more than a young labourer  
or bride-to-be.

**She is a future leader,  
a change-maker,  
a flourished dream.**



**Room to Read®**

Room to Read has given 50,000 girls  
in low-income countries the confidence-  
building curriculum to reroute their  
lives and mentors to help them navigate  
life's toughest choices.

Fuel her Future at  
[RoomtoRead.org/GirlsEducation](http://RoomtoRead.org/GirlsEducation)







Communities  
In Schools

# In schools to unlock potential.

At the beginning of his freshman year, Jalen's ambition wavered. He lost sight of his goals and found himself straying from his path. Toriano from Communities In Schools became his trusted guide, working with Jalen to improve his attendance, raise his GPA and set clear goals for the future. Now a senior, Jalen is a first-chair trombone player and drum major in his high school marching band. He's exploring musical scholarship opportunities for college, and he has dreams of becoming a U.S. Marshal. There are millions of at-risk kids like Jalen who need a caring adult to help them stay in school and succeed in life.

See how we help all kids succeed. | [CommunitiesInSchools.org](https://www.CommunitiesInSchools.org)



● A battle has erupted for control of Tripoli, the capital of Libya.

Eight years after the uprising that ended Moammar Al Qaddafi's 40-year rule, warlord Khalifa Haftar is trying to topple the internationally recognized government of Prime Minister Fayez al-Sarraj.

● Turkish President Recep Tayyip Erdogan is pushing for a revote in Istanbul. His ruling party suffered an apparent defeat in the city—his power base—in March's regional elections. Erdogan alleges there were "widespread irregularities" and "organized" fraud.

● Scientists from the Event Horizon Telescope collaboration presented the first photos of a black hole, at the heart of Messier 87, a galaxy 55 million light-years away.



● Saudi Aramco received more than

**\$100b**

in orders for its debut bond sale. This marks a turnaround for Saudi Arabia, which has been shunned by investors and Wall Street bankers since the assassination of journalist Jamal Khashoggi.

● Kirstjen Nielsen was forced out as head of the U.S. Department of Homeland Security, part of a broader purge at the agency by President Trump as he seeks to crack down on immigration.



● In an IPO, probably in May, Uber will seek to raise about

**\$10b**

according to people familiar with the matter. The offering is expected to be the U.S.'s biggest this year and among its 10 largest ever. Word of the offering sent shares of rival Lyft, which had its IPO in late March, plunging.

● Apple's stock is on a tear—including a nine-day winning streak that started in late March—gaining more than 40 percent from its January low.



● The U.S. is weighing tariffs on

**\$11b**

of European products ranging from cheese to ski suits, in retaliation for what it called unfair Airbus subsidies that are hurting American rival Boeing.



● Wynn Resorts abruptly aborted a \$7 billion takeover of Australia's Crown Resorts that would have opened a new market for the gambling company. Wynn blamed the sudden retreat on the premature disclosure of the negotiations in an Australian newspaper.

● "This is not about greed. This is not about dictatorship. This is about a plot. This is about conspiracy. This is about backstabbing."

In a seven-minute-long video message, former Nissan executive Carlos Ghosn lashed out against the circumstances surrounding his repeated arrests in Japan on allegations of financial misconduct.



- Magic Johnson abruptly resigned as president of the Los Angeles Lakers, two years after taking charge of the franchise.
- Société Générale said it plans to cut about 1,600 jobs, almost half of them at home in France.
- Global executions fell by almost a third last year, to about 690, the lowest in at least a decade, Amnesty International said.
- Netflix is in talks to buy the Egyptian Theatre in Los Angeles, which it plans to use for screenings and premieres.



## ► Can They Go Much Higher?

Last year was the most profitable in banking history. So expectations are high as some of the biggest financial names report first-quarter earnings: Goldman Sachs and Citigroup on April 15, followed by Bank of America the next day, and Morgan Stanley on April 17.

► China releases economic data on April 17, including first-quarter GDP and the latest retail sales and industrial production, amid trade tensions with the U.S.

► Netflix reports first-quarter earnings on April 16. The company is relying on its international business for growth as the U.S. market becomes more saturated.

► The Bank of Korea unveils its rate decision after an April 18 policy meeting. Central banks worldwide are pausing rate hikes as economic growth slows.

► Indonesia's 190 million eligible voters will pick a president on April 17. Incumbent Joko Widodo is trying to stave off challenger Prabowo Subianto.

► The Auto Shanghai motor show starts on April 16. Car demand in China has declined for 10 straight months as growth slows and the trade war lingers.

► The annual Coachella music festival kicks off the first of two weekends on April 12. This year's headline acts include Tame Impala and Ariana Grande.

## ■ BLOOMBERG OPINION

8

# Nigeria's Time Bomb

● Unless newly reelected president Buhari acts quickly, the country's demographics may overwhelm the economy

In 2000, some 1.4 billion people lived at or below the global poverty line of \$1.90 a day. Today, the number is about 600 million. This remarkable change is mainly due to growth in China and India: Much of sub-Saharan Africa, particularly Nigeria, has failed to share in the success.

A decade ago, Nigeria had far fewer people in extreme poverty than either China or India; today, according to data compiled by the World Data Lab, it has more than both combined. The count stands at more than 90 million and has risen both in absolute terms and as a share of the total.

Nigeria's success or failure in confronting extreme poverty will be pivotal for the rest of Africa—partly because of its huge population but also because of its outsize influence over its neighbors. The government led by President Muhammadu Buhari, recently reelected to a second and final four-year term, bears a grave responsibility. One wonders whether a politician known as Baba Go Slow is up to the task.

His record is discouraging. Growth has barely recovered following the 2014 crash in the price of oil, which remains Nigeria's biggest export and source of government revenue. Islamic extremists such as Boko Haram and Islamic State remain a serious threat, violence persists in the oil-rich Niger

Delta, and environmental pressures resulting from climate change have stoked clashes between herders and farmers. The country also has the world's second-largest number of people suffering from HIV/AIDS and faces huge burdens from tuberculosis, malaria, and other diseases. Governance remains weak, corruption and crime rampant.

Buhari retains a reputation for personal integrity and the commitment to fight graft. But he needs to give equal weight to economic revival, without which there will be little progress in quelling conflict and radicalism. In particular, he has steadfastly resisted devaluing Nigeria's currency, likening a depreciation to "murder" because of its impact on the prices of imported fuel and food. Nigeria should aim to float its currency, as proposed by the International Monetary Fund and Atiku Abubakar, Buhari's challenger in February's election.

Economic reform could also lure more foreign direct investment—which is sorely needed, especially in infrastructure. To fund public investments, Buhari's government will need to boost nonoil revenue through better tax compliance and enforcement. Until the tax system is fixed, further reliance on debt would be unwise: Nigeria collects relatively little revenue, so debt service eats up most of the budget. It already accounts for 60 percent of federal revenue, and the figure is expected to rise to more than 80 percent by 2022—a level the IMF calls "unsustainable."

The country that could be Africa's dynamo is instead its biggest demographic time bomb. Before it's too late, Baba Go Slow needs to hurry up. **B**

Written by the Bloomberg Opinion editorial board

# Join us for the 49th annual Matrix Awards on May 6th



## MATRIX AWARDS

NEW YORK WOMEN IN COMMUNICATIONS

Women are being heard. The tides are changing in the workplace.

Join us as we celebrate the 2019 Matrix Awards honorees for their outstanding contributions and achievements.

Invest in equality: Proceeds from the Matrix Awards go toward a full range of scholarships and educational programs for women at every stage of their careers.

HOSTED BY **Bloomberg Media Group**

### 2019 MATRIX HONOREES INCLUDE:



### MATRIX EMCEE

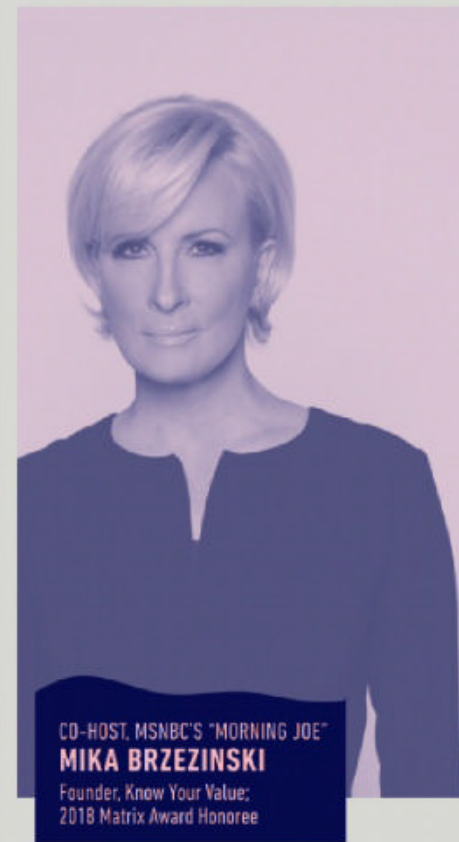

### 2019 MATRIX PRESENTERS INCLUDE:



SHOW YOUR SUPPORT THROUGH SPONSORSHIPS, TABLES AND TICKETS AT [NYWICI.ORG](http://NYWICI.ORG)



**I'M NOT JUST HERE TO PUT  
IN THE HOURS. I'M HERE TO  
PUT IN THE YEARS.**

---

Look beyond the resume and you'll find the skills you're looking for. Grads of Life are an untapped pool of motivated, dedicated and driven talent. Discover new ways to develop great talent at [GradsOfLife.org](https://GradsOfLife.org).



**GRADS**  
*of* **LIFE**  
.org

# The Trouble With England

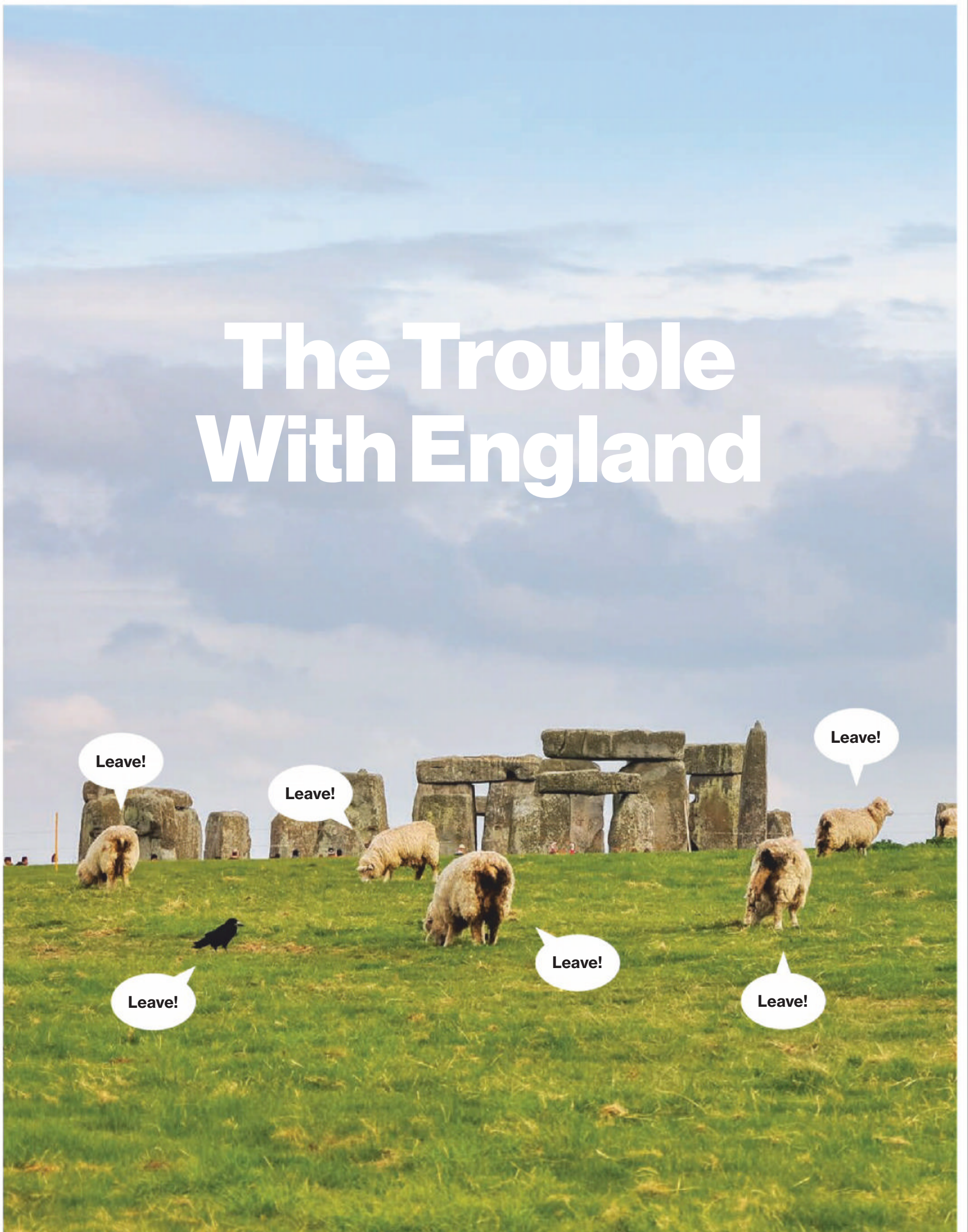

## ● Most people equate “British” with “English,” but there’s a painful disconnect at the heart of Brexit

● By Alan Crawford

At first glance, there’s little to betray the village of Edington’s status as the lodestar of Brexit. Squeezed between the chalk hills of Salisbury Plain and Wiltshire’s clay downs to the north, Edington lacks a school, a shop, or an obvious center. It has a village pub, the Three Daggers, and an ornate priory church serving a population the 2011 census put at 734 souls.

It’s here, though, that historians broadly agree England was born. And England is key to understanding what’s happening in the U.K. today. For if anything is clear from its tortuous divorce from the European Union, the spectacle of an angry and divided nation in desperate need of direction is an English phenomenon, not a British one.

Edington lies in an ancient landscape dotted with Neolithic long barrows and overlooked by an Iron Age hill fort. It’s Anglo-Saxon country, the heart of the onetime kingdom of Wessex. Some 400 years ago, a giant figure of a horse was cut into the chalk: It’s thought to commemorate a decisive victory by King Alfred over a marauding Viking army. Jacob Rees-Mogg, the Conservative lawmaker, cites Alfred and his triumph over the pagan Danes at this spot in 878 A.D. as political inspirations. Edington, the Brexit cheerleader has said, is the site of “the great battle on which our freedoms depend.” Alfred the Great, as he is known, “wanted to tell people what ancient rights they had and how they ought to have their liberties,” Rees-Mogg told the House of Commons in 2010 in his maiden speech after winning a parliamentary seat in the nearby county of Somerset. Alfred’s grandson “became the first King of England on borders we would recognize to this day.”

Back then, Eton-educated Rees-Mogg was considered a fringe figure whose attempts to re-create England’s past greatness were disregarded as curious anachronisms. Now he chairs the European Research Group of hard-line Brexiters, and his notion of a besieged England standing up to defend its values is mainstream among those seeking to shake off the EU’s yoke.

There are many reasons behind Brexit, from concerns over immigration and globalization’s impact, to an urge to regain the nebulous concept of sovereignty (take back control), or simply to kick the establishment. But at its emotional core is an increasingly disaffected England struggling to find its role in the world. When Brexiters carry placards saying “Believe in Britain,” they really mean “Believe in England.”

Of the U.K.’s four constituent nations, two—England and Wales—voted to leave the EU in the 2016 referendum. Scotland and Northern Ireland chose to remain; not a single

Scottish council area saw a majority vote for leaving. Yet England’s population outweighs that of the rest of the U.K. by more than 5 to 1, so it will drag the others out, anti-Brexit London included.

As the process has run into trouble, there are indications that pro-Brexit voters in England are doubling down rather than reconsidering their choice. An April YouGov poll suggested that every English and Welsh region other than London would be happy to quit the EU without a deal, risking the threat of economic harm, trade chaos, and shortages in stores and hospitals to get their way. In one of the many recent Brexit votes at Westminster, 160 members of Parliament—two-fifths of the total—supported such a “No Deal” exit, 156 of them from constituencies in England. Edington’s Conservative MP, Andrew Murrison, was among them.

Thanks to the results of the Brexit referendum, the contours of resentment are clearly delineated. Winchester, the royal residence of King Alfred and home to one of England’s great cathedrals, forms the western periphery of the Remain vote emanating from the capital. Beyond, it’s near-uniform Leave territory all the way to the Celtic Sea. This is the England that’s lost its voice, that feels ignored by and alienated from its multicultural, cosmopolitan capital, says John Denham, director of the University of Winchester’s Centre for English Identity and Politics and a former minister in Tony Blair’s Labour Party government.

Surveys, including one of 20,000 people conducted with the help of the BBC last year, show that these people tend to be older, haven’t been to university, and live in smaller places that have lost their purpose. They also tend to identify as being more English than British. The result is a deep unease at large in much of England that urgently needs to be addressed. “It would appear that Englishness is becoming the identity of people who are least comfortable with change in the modern world,” Denham says. “These divisions were there before Brexit. Brexit revealed them, it didn’t create them. The great danger is that it’s not dealt with and that it will continue to break out in disruptive ways.”

What is it to be English today, shorn of the British Empire, its World War II victories and sacrifices fading in memory? Conservative Prime Minister John Major, another occupant of 10 Downing Street bedeviled by arguments over Europe, made a stab at it in 1993. “Fifty years on from now,” he said, “Britain will still be the country of long shadows on county grounds, warm beer, invincible green suburbs, dog lovers, and pools fillers and, as George Orwell said, ‘Old maids bicycling to holy communion through the morning mist.’” In reality, only dogs and filling in the pools—a form of weekly lottery—were British; everything else listed was archetypal England.

England and Britain are often used interchangeably in places such as Germany and the U.S. The English, as the dominant force in the 312-year-old union, have traditionally not minded much. But that began to change around the turn of the century, when surveys showed differences in attitude emerging between those who identify as ►



◀ more English than British and those who see themselves as predominantly British. The identities aren't mutually exclusive, but there are political differences: Those describing themselves as English are more likely to vote for the UK Independence Party or the Conservatives, while those who say they're British are more likely to vote Liberal or Labour. Those calling themselves English were overwhelmingly more likely to vote for Brexit.

This bifurcation between the identities can be traced back to the Blair government's election in 1997 on a commitment to parcel out powers from London under a policy known as devolution. The Scottish Parliament was reconvened in 1999, almost 300 years after it was adjourned at the onset of the union; the Welsh Assembly was established the same year. The Good Friday Agreement of 1998 also created a Northern Ireland Assembly, while London got its own assembly in 2000.

England would have to wait another five years for its turn. But even then the elected assemblies proposed for the English regions by Deputy Prime Minister John Prescott were toothless, with no power to draft laws. Voters in the pilot region of North East England resoundingly rejected the body in a vote in November 2004. The plans were quietly dropped.

Since then, Scotland, Wales, Northern Ireland, and even London have been forging their own identities. England hasn't had that chance—its only legislative outlet is the U.K. Parliament in London. There, England has had to witness the humiliation of a Conservative government dependent upon Northern Ireland's hard-line Democratic Unionist Party for votes; it's looked on impotently as Ireland dictates the terms of Brexit; and it's watched a pro-independence Scottish government that tries to appear more concerned about the union's future than that of its U.K. counterpart.

Those who perceive England to lack a voice in domestic matters are the same people most concerned about EU regulations and migration, according to Ailsa Henderson, a professor of political science at the University of Edinburgh, who analyzed the results of the 2018 Future of England Survey. "The U.K. is not now, nor has it been for a long time, a union of shared identities," she wrote in a December paper, "Brexit, the Union, and the Future of England." "The more English one feels, the more likely one is to express dissatisfaction with each of England's two unions, one external, the other internal."

For Jacob Funk Kirkegaard, a senior fellow at the Peterson Institute for International Economics in Washington, who happens to be a Dane like King Alfred's vanquished opponents, the Brexit vote was evidence of "an element of English nationalism" that's stirred up a hornet's nest. The end result could be a federal U.K., Irish unification, Scotland going its own way, or even England's secession from the union. Identity politics has gained the upper hand; traditional parties lose their relevance as voters identify as pro- or anti-Brexit. "The pervasive sense of uncertainty surrounding the U.K.'s role in the world, relationship to Europe, cohesion among itself as a country, its political system—that's going

to continue," he says. "That damage has been done. There's nothing that can be done to undo that now."

As a Scot living in Berlin, I've looked on in horror at the unfolding Brexit debacle. I've taken it as a personal affront, and it's prompted me to seek German citizenship. But having covered the early days of the Scottish Parliament and Executive—later renamed the Scottish Government—I can relate to attempts to reinvent Scotland as a progressive place open to the world, and I understand English frustration at not having the same opportunity.

Denham, of the Centre for English Identity and Politics, favors the term "nationhood" to "nationalism," though he concedes far-right forces such as the English Defence League are working hard to occupy the space opened up by Brexit's focus on identity. He sees a need to establish a Parliament to handle specifically English matters and to reinvent a new narrative to save the union. Brexit, he says, is an historic moment that offers the chance to build a new national identity that takes the English into account. He admits that his is a minority view.

The road from Winchester to Edington, from Remain to Leave country, offers impressions of one version of England's identity. It's a lush landscape of pheasants and badgers, judging from the number of dead animals on the roadside; of ancient monuments, including the megalithic circle of Stonehenge; and country pubs with names like the Rose & Crown and the Churchill Arms. But those rustic images are set against the reality of the vast military training ground that is Salisbury Plain. Chinook helicopters fly overhead, red flags denote live firing exercises, and road signs warn of tanks crossing and "Danger: unexploded bombs."

It's perhaps no coincidence that Brexiters often turn to historic battlefield analogies in their search for parallels with Brexit, the paradox being that the EU was formed to promote peace. UKIP's former leader, Nigel Farage, wore ties depicting the Battle of Hastings, in 1066, where the English King Harold fought the invading Norman force (and, in the popular account, took an arrow in the eye as his army fell to defeat). Nick Timothy, Prime Minister Theresa May's former chief of staff, urged her in an op-ed in the *Sun* to "find her inner Boudicca" in negotiations with the EU—a reference to the first century rebellion led by the warrior queen of the indigenous Iceni tribe, which was ultimately crushed by the Roman occupiers.

Edington seems a more apt analogy, and Alfred a less divisive figure as the first consciously English nation builder. Yet there's no monument to him in the town: It wasn't until the year 2000 that a modest sandstone memorial was raised by the hill fort at nearby Bratton Camp, the inscription paying tribute to Alfred's victory, "giving birth to English nationhood."

The English nation will be asserting itself anew—whatever the outcome of the chaotic divorce from Europe. "If anything is clear from our data, English dissatisfaction with the union is unlikely to go away with time," says Edinburgh's Henderson. "Or with Brexit." **B**

**MY DAUGHTER  
JUST RELAPSED  
NOW WHAT?**

**WE CAN HELP.  
TEXT 55753  
TO CHAT WITH A SPECIALIST.**



**Partnership™  
for Drug-Free Kids**

Where families find answers

If you find yourself in a situation you never thought you'd be in, we're here to help. No matter what you and your family are going through, we can help you take on your child's drug or alcohol problem.

**Connect with a Parent Specialist for free.  
Call 1-855-DRUGFREE or Text 55753**

# When Groceries Have Cult Appeal

● Wegmans's star power will be tested when its first New York City supermarket opens

Most 60-year-old men don't go food shopping every day, but Tommy Mule does. Mule (pronounced Moo-LAY), a morning radio host in Rochester, N.Y., pops into his local grocery store daily for some Vietnamese spring rolls, a rotisserie chicken, or just a coffee and some chitchat with Jimmy, his pal in the produce department.

The broadcaster likes the place so much he hired the supermarket to cater his wedding. He often takes out-of-town guests on a tour of the place. "They say, 'It's a goddamn grocery store. How good could it be?'" he says. "But I say it's the best shopping experience you've ever had."

Mule's retail nirvana is Wegmans Food Markets. If you haven't heard of it, you're not alone. The privately held, family-run chain based in Rochester has only 98 stores scattered across six eastern states, fewer than Walmart operates in New York state alone. But it punches well above its weight, combining the product breadth of a Walmart, the quality of a Whole Foods, and the quiriness of a Trader Joe's.

While its sales of about \$9.2 billion are puny compared with supermarket giants such as Kroger Co. and Safeway Inc., Wegmans has proved adept at solving the most intractable problem facing U.S. retailers—giving shoppers a compelling reason to visit its stores. Wegmans has been ranked as the nation's top grocery store for the past three years, according to a survey of shoppers by researcher Market Force Information. Sales per square foot at Wegmans are higher than those of any other supermarket chain save for Whole Foods, according to Creditintell, a retail credit consulting firm. It's become a harbinger of hope for a retail industry that's reeling from store closures, the proliferation of discounters like Germany's Aldi, and Amazon.com

Inc.'s encroachment into all things retail. "The entire U.S. grocery sector is hurtling towards a day of reckoning," says Neil Saunders, an analyst at GlobalData Retail. "There is simply no avoiding this pain and ultimately the battle will be about surviving rather than thriving." Wegmans, though, is doing more than surviving, Saunders says, as it's "head and shoulders above most U.S. grocers."

While many grocery stores have folded—think onetime industry leader A&P or Chicago's Dominick's—Wegmans is going all out in one of the biggest and most competitive markets in America: New York City. This fall, the chain will open its first big-city location, a 74,000-square-foot facility at the Brooklyn Navy Yard, in a long-ignored tract of the former military base called Admiral's Row, where officers' residences once stood. The move will be a big test of whether Wegmans's can duplicate the phenomenal success it's had in smaller locales in the crowded New York market.

In 2015 the Brooklyn Navy Yard Development

## Spreading the Wegmans Gospel

● Existing locations ● Planned locations

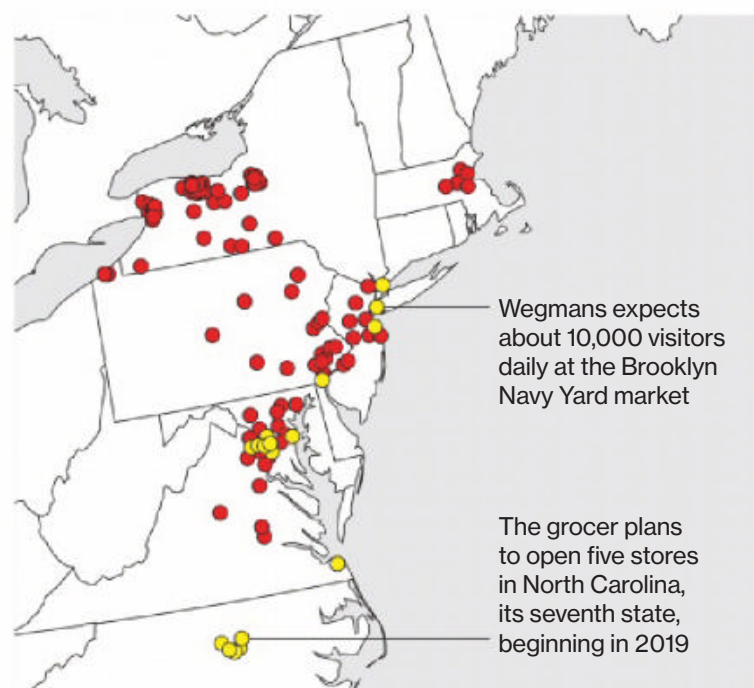



◀ Inside the Wegmans in Natick, Mass.

Corp. (BNYDC)—a not-for-profit that manages the yard on behalf of its owner, the City of New York—handed the Admiral’s Row development contract to Doug Steiner. His television and film production studio complex at the Navy Yard is the largest outside of Hollywood. Wegmans, Steiner says, “is the best supermarket in the country,” and “instills a corporate culture that’s almost like a cult.”

Key to that reputation is the grocer’s 49,304-strong staff, a quarter of whom have been with the company for a decade or more. Wegmans is known for flying employees to Sicily for a week to learn how to make ricotta. When Wegmans’s workers say the company is like a family, it’s not just public-relations spin: About one-fifth of its staff are related.

The enthusiasm extends to its most-loyal shoppers, known as Wegmaniacs. When Buffalo Bills offensive lineman Richie Incognito renewed his contract to remain with the team a few years ago, he tweeted, “Not gonna lie... Wegmans was a big part of me re-signing in Buffalo.” And when Wegmans in 2011 opened its first store in Massachusetts, a local high school staged a musical about it.

Feeding the obsession is the store’s range of exclusive offerings, like its extensive assortment of take-home meals, developed in part by celebrity chef David Bouley. There’s also the cheese counter, with 350 varieties—including esquirrou, a hard sheep’s milk varietal from the French Pyrenees named the world’s best cheese in 2018—that are

perfect for pairing with one of Wegmans’s 2,200 wines. Beyond such specialties, the store also carries everyday items like Cocoa Puffs and Coca-Cola, at prices no higher than at other local markets.

Brooklyn presents a huge opportunity for Wegmans: the 2.8 million people who live within 5 miles of the Navy Yard, with an average household income well above \$100,000. But there are serious challenges, too. Big, crowded cities aren’t conducive to Wegmans’s sprawling stores. The Navy Yard is isolated, a food desert abutting a public-housing project, and is cut off from most of the borough by the Brooklyn-Queens Expressway. And New York City’s grocery scene is a hypercompetitive mix ranging from bodegas and street-corner produce stands to local chains like Fairway and D’Agostino that have more experience with the hefty and rising operating costs that have eaten away at area grocers’ margins.

“The business has changed,” says John Catsimatidis, owner of a company that operates 35 local grocery stores under the Gristedes and D’Agostino banners. “When you’re being attacked five different ways, everyone takes a percentage, and you’re f---ed.”

Brooklyn is a decidedly different kind of project for Wegmans, presenting plenty of design challenges. The new building will house several floors of light-industrial manufacturing above the store, so an elevator shaft had to be installed for those businesses that wouldn’t infringe on the store’s layout, ▶

● Price of a basket of common groceries  
○ Regular price  
● Including promotions

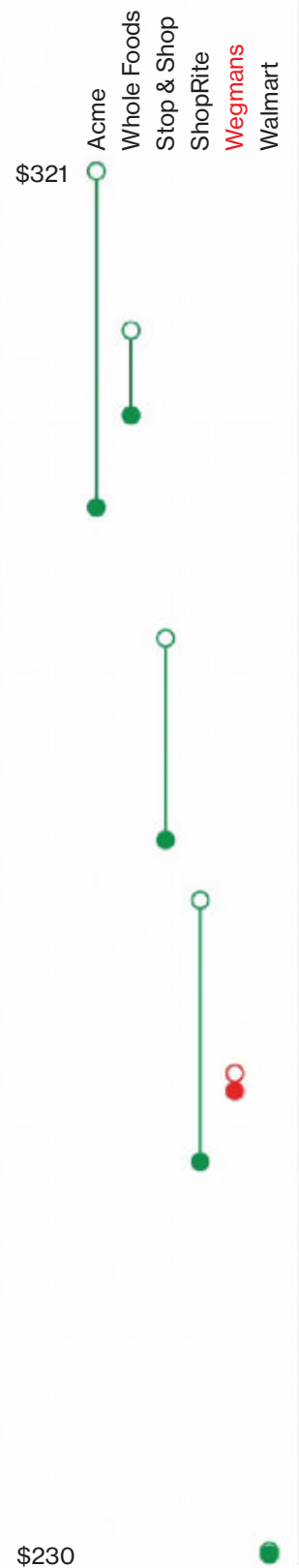

PHOTOGRAPHS BY AMY LOMBARD FOR BLOOMBERG BUSINESSWEEK. DATA: COMPANY REPORTS; BLOOMBERG INTELLIGENCE PRICING STUDY OF 74 ITEMS SOLD AT GROCER LOCATIONS IN NEW JERSEY, CONDUCTED ON MARCH 19

◀ which includes a mezzanine cafe and wine bar that will seat more than 100. A bigger concern is climate change: Hurricane Sandy in 2012 flooded the yard, so the site has been raised by an average of 5 feet to reduce the risk of a repeat.

“All this was new for Wegmans,” says Navid Maqami, co-founder of architectural firm S9, which designed the Navy Yard store’s exterior. “Things are a little different here.” Take the windows: Most grocers use tinted glass to lower energy costs, but this Wegmans will install low-iron glass that’s more typically used by luxury retailers and easier to see through. For Wegmans to be a destination, Steiner figures, shoppers need to know what’s inside.

The grocer has adapted to new environments before. Last year it opened its first mall-based location in the Boston suburb of Natick. Wegmans built a shopping cart escalator for its two-level store and a skywalk that connects to an 1,800-car garage.

Parking has been a sticking point in Brooklyn. Steiner thought the store needed only about 250 spots since many New Yorkers don’t own cars, but Wegmans executives, expecting shoppers to drive from up to one hour away, insisted on more. So a parking garage with 429 additional spots is going up next to the store. There will also be dedicated spaces for Uber pickups—a New York necessity.

Still, perhaps the biggest challenge will be convincing New York’s notoriously finicky shoppers that Wegmans, unfamiliar to many locals, offers something unique. “I’ve been to Wegmans in Rochester,” says Ariel Lauren Wilson, editor-in-chief of *Edible Brooklyn* magazine. “Did I feel it was anything I couldn’t get in New York City? No.”

Wegmans isn’t planning any big changes to its product assortment for Brooklyn, according to Chief Executive Officer Colleen Wegman. “There are all different types of customers there, so we will offer the best of what we have,” she says.

The chain seems poised to take sales from supermarket rivals, according to Earnest Research. Since Wegmans entered Natick, for example, customer visits and spending at the nearby Whole Foods have declined by more than 20 percent among shoppers that visit both stores. “Whole Foods could be in real trouble in Brooklyn,” says Michael Maloof, Earnest’s senior grocer analyst.

The Navy Yard store’s 500 employees will include many local residents. Of the 4,000 applications Wegmans received in January, 741 have come through the Navy Yard’s employment office. Of those, 30 percent are residents of Farragut Houses, a city housing project adjacent to the site, and two other local housing projects. New hires will work alongside lifers like store manager Kevin Cuff, who



▲ The chain’s first mall-based store, outside of Boston

started with Wegmans as a teenager 21 years ago. He’s not unique: More than half of store managers started with Wegmans as teens, then stayed in part because of perks such as college scholarships, which totaled \$5 million last year.

Unlike Amazon, which scrapped plans for a headquarters in Queens after opposition from some local lawmakers, Wegmans so far has received a warm welcome from New York City’s politicians and activists. But there are no guarantees in the big city. Colleen’s father, Chairman Danny Wegman, whose grandfather and grand-uncle founded the chain in 1916, admits as much. “We have no idea what’s going to happen,” he says. “But if you like people and you like food, that’s what our business is. It’s no more complicated than that.” —*Matthew Boyle*

THE BOTTOM LINE Brooklyn is a huge opportunity for Wegmans: 2.8 million people living within 5 miles, with an average household income over \$100,000.

# Fiat Is Stalling In the U.S.

● Sales of the tiny Italian cars have been hurt by cheap gas and the shift to big SUVs

When the lease was up on Ed Kim’s 2015 Fiat 500L, he and his wife went through four Los Angeles area dealerships before they found one willing to take back the car. Three had dropped the Fiat brand from their stores—including the one that originally leased him the car. “We had this orphaned car in

our driveway that we needed to bring back, with no dealership willing to take it in,” says Kim. “It was such a weird and bizarre situation.”

Kim’s troubles are a sign of just how much Fiat Chrysler Automobiles NV’s American experiment with stylish Italian microcars has failed to live up to expectations. Fiat brand sales in the U.S. peaked at about 46,000 in 2014, with the addition of the roomier 500L, and have been in free fall ever since. They were down 45 percent year-over-year in the first quarter of 2019, after a 41 percent plunge last year to 15,521, the lowest level since the brand’s reintroduction to the U.S. in 2011.

Fiat’s misadventures in the U.S. are perhaps a lesson in the futility of trying to get Americans to buy compact cars. A decade ago, as gas prices shot above \$4 a gallon and General Motors and Chrysler teetered on the edge of bankruptcy, small cars seemed like a gaping hole in Chrysler’s lineup and the key to a more stable, environmentally friendly future. A decade later, trucks, SUVs, and vans make up 70 percent of new U.S. car sales, and the Italian-American automaker is as dependent as ever on American demand for pickups and sport utilities to turn a profit. “The Fiat brand is 99 percent dead at this point,” says Alan Haig, president of Haig Partners LLC, a brokerage that helps dealers buy and sell franchises. “My guess is Fiat Chrysler is just going to pretend this problem doesn’t exist and let it solve itself—and let people eventually close the doors of Fiat dealerships.”

Officially pulling the plug would be a costly exercise for the automaker, since franchise laws dictate that it would have to buy back inventory from dealers to terminate the brand, Haig says. Fiat Chrysler declined to comment for this article.

Fiat Chrysler offers four models in North America: the Fiat 500, 500X, 500L, and the 124 Spider, and it’s coming out with a 2019 500X with an all new turbo-charged engine and a special edition of the Spider this spring. The company’s five-year strategic plan calls for trimming the Fiat lineup to focus on premium models and a fully electric family of cars designed around the 1950s-inspired Fiat 500. People familiar with the plan said the company would focus the brand on Europe, Brazil, and emerging markets, implying a potential withdrawal from the U.S. and also China, where the small cars have failed to gain traction.

Fiat’s China website still shows three models, though a dealer at Beijing Changyi Auto Sales and Service Co. said the cars haven’t been available in Beijing for some time, while another at Zhongshan Zhongmeichang Auto Service Co. in Guangdong

said she’d been told by Fiat Chrysler that the brand was withdrawing from China.

Sergio Marchionne, the late chief executive of Fiat Chrysler who spearheaded Fiat’s return to the U.S. market, insisted on costly standalone stores, dubbed Fiat studios, and ad campaigns featuring Jennifer Lopez and Charlie Sheen. Marchionne himself acknowledged his folly a year into the Fiat initiative: “We thought we were going to show up and just because of the fact people like gelato and pasta, people will buy it,” he told reporters at the Detroit auto show in 2012. “This is nonsense.”

Today, there are only six standalone Fiat stores left in the U.S., compared with 30 when the brand was reestablished there. The remaining 377 Fiat franchises are attached to Chrysler Dodge Jeep Ram dealerships or Alfa Romeo stores, the result of a 2016 consolidation to help dealers cut costs and boost sales.



▲ Fiat’s 2019 500X crossover

### Mini Car, Micro Sales

Change in Fiat Chrysler’s U.S. vehicle sales, by brand, from March 2015 to March 2019

Bar width indicates number of vehicles sold in March 2019

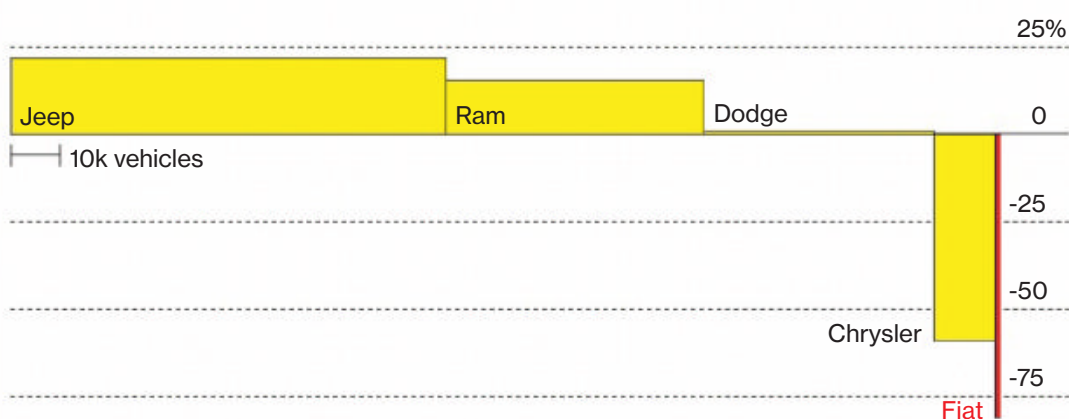

DATA: EDMUNDS

Bill Golling, who owns two Fiat franchises outside Detroit, said the brand is the victim of cheap gas prices more than anything else, something that’s afflicted the entire U.S. small-car segment. Fiat Chrysler’s marketing budget for the brand is “on pause,” he says. “If gas was \$6 a gallon, we’d be brilliant having Fiat here,” he says.

Fiat can’t place all the blame on gas prices and consumer whims. Earlier this year, the brand ranked dead last among 33 in *Consumer Reports* magazine’s brand report card. The 2019 500L was named the worst car in the compact-car category. The company says the ranking was skewed by “limited models and sample sizes.”  
—Gabrielle Coppola, with Yan Zhang

**THE BOTTOM LINE** In 2011, Fiat had high hopes for its microcars in the U.S. Today, SUVs, trucks, and vans make up 70 percent of U.S. new vehicle sales, leaving Fiat in the slow lane.

# SoftBank And Ola Face Off

● The Indian ride-hailing startup says thanks, but no thanks to Masayoshi Son

When startups raise venture money to build their businesses, they begin with a Series A round and then proceed through Series E, F, or maybe G before going public. The Indian ride-hailing service Ola just completed its Series J fundraising and is marching toward Series K, a letter almost unheard of by people who track such things.

What's going on here involves more than money. Ola co-founder Bhavish Aggarwal is fighting to maintain his independence against SoftBank Group Corp. The Japanese conglomerate, led by Masayoshi Son, was an early backer of Ola. But Aggarwal has grown concerned about SoftBank's influence after it took a stake in his archrival, Uber Technologies Inc., and then encouraged the two to merge.

With his \$100 billion Vision Fund, focused on investments in fast-growing tech companies, Son has offered to put more money into Ola. But Aggarwal doesn't want SoftBank to gain more sway. So instead of taking \$1 billion or more from Son, he's pieced together smaller slices of funding from unaligned backers. So far in 2019, he's picked up \$300 million from Hyundai Motor Co. and about \$90 million from Sachin Bansal, co-founder of Flipkart Online Services Pvt. In January share allotments were also made to Steadview Capital and a few others.

"Bhavish is spurning SoftBank money as he doesn't want to get diluted out of Ola," says Mohandas Pai, venture capitalist and former chief financial officer of Infosys Ltd. "Founders become employees when someone sits on your board and tells you how to run the show."

Aggarwal avoids gatherings with the SoftBank founder when Son visits his portfolio companies in India, say people familiar with the matter. For example, Aggarwal wasn't at a meeting of SoftBank-backed





founders when a delegation including Saudi Crown Prince Mohammed bin Salman visited, the *Economic Times* reported. Saudi Arabia contributed nearly half the capital for Son's Vision Fund.

Aggarwal has also gone to the founders of Indian e-commerce platform Snapdeal for advice on dealing with SoftBank, the people said. SoftBank invested in Snapdeal about five years ago and then tried to push its founders to sell out to a larger rival, Flipkart. When Snapdeal refused the deal, Son switched allegiances: He stopped further investment in the company and put \$2.5 billion into Flipkart.

Bangalore-based Ola denies there's a rift with the Japanese company. "SoftBank has been a great partner for us as we've grown our business," a spokesman for the company says. "There are so many emerging synergies with SoftBank that we envisage in the years to come, as we continue to build a global mobility business out of India." A SoftBank spokeswoman says, "We enjoy a cordial relationship with all our portfolio companies, including Ola."

Son was an early champion of local ride-hailing startups in Asia. He backed Anthony Tan's Grab in Southeast Asia and Cheng Wei's Didi Chuxing in China, in addition to the early investment in Ola in 2014. The relationship between Son and Aggarwal was warm early on. "He is inspiring and aggressive and a visionary. He is making history," the Indian entrepreneur told *Nikkei Asian Review* even as recently as last May.

But the dynamic had already changed after SoftBank spent about \$9 billion to become the largest shareholder in Uber in January 2018. Ola and Uber are bitter rivals in India, competing for customers and drivers. SoftBank has more at stake with Uber and needs it to succeed to demonstrate the potential of its massive Vision Fund. The San Francisco-based ride-hailing giant is said to be preparing an initial public offering to be valued at as much as \$120 billion.

Ola, valued at about \$6 billion, is far from an IPO. It's raising tiny rounds, collecting as little as \$50 million from investors. "In the Indian e-commerce universe, there are very few investors who will write big checks of half a billion dollars or more," says Gautam Chhaochharia, managing director and head of India research at UBS Securities India Private Ltd.

Ola currently has 1.3 million drivers on its platform in more than 100 cities. Over the past year it's expanded to Australia, New Zealand, and the U.K. The company also got into food delivery by acquiring the operations of Foodpanda in India.

Soon after SoftBank became Uber's largest shareholder, executives at the Japanese conglomerate floated the idea of a merger between the rivals ►

**"Founders become employees when someone sits on your board and tells you how to run the show"**



◀ in India, according to people familiar with the matter. When Aggarwal resisted, SoftBank attempted to buy out the stake of another Ola investor, Tiger Global. But by then Ola had modified its corporate bylaws so that any sales between investors would need approval of the board, including Aggarwal, and the Softbank-Tiger deal died.

Merger talks are now off. Uber sold its operations in Southeast Asia to Grab last year, a move that trimmed its losses but also cut off growth potential in an important region. India is sure to be highlighted as a key example of overseas opportunity when Uber files its IPO paperwork.

Meanwhile, Aggarwal appears to be girding for an onslaught. He's collecting cash and hoarding what he can. Ola has become more prudent with its spending, cutting incentives for drivers and trimming subsidies for both its ride-hailing and food delivery businesses. "It's a good strategy," says Pai, the venture capitalist. If Aggarwal expects Uber—and SoftBank—to come after him again, he'll need all the money he can get to protect his business. —*Saritha Rai*

THE BOTTOM LINE Aggarwal has been concerned about SoftBank's influence over Ola ever since the Japanese conglomerate took a big stake in archrival Uber.

# Clues to an Identity

● A cousin's DNA made it possible for a researcher to quickly connect the data to one of our reporters

22

Using just my DNA, a genealogist was able to identify me in three and a half hours.

It wasn't hard. I'd previously sent a DNA sample to the genetic testing company 23andMe Inc. and then uploaded my data anonymously to a genealogy website. Researcher Michelle Trostler was able to access my data from that site and spent an afternoon looking for connections that would help her put a name to my data. The task was so easy that in the meantime she rewatched a season of *Game of Thrones*.

Law enforcement officials are increasingly using similar tactics to find and catch suspected criminals. Crime scene DNA gets uploaded to popular genealogy websites GEDmatch or FamilyTreeDNA that have given officials access to their databases. Genetic genealogists then look for DNA relatives of anonymous suspects, scouring public records and social media until they arrive at a likely name. That's how California investigators found the suspected Golden State Killer last April.

The boom in consumer DNA testing has been a boon for criminal investigations. Over the past year investigators worked with genetic genealogists to identify suspects in more than 60 cases, most of them long cold. The suspects didn't volunteer any information. Instead, they were tracked down using data shared by family members. Law enforcement can take a DNA sample, analyze it, and use relatives who match that DNA on one of

the genealogy sites to develop an anonymous person's family tree and identify them.

These cases highlight the intimate nature of DNA data. Anyone can be exposed, whether or not they've made their own DNA public. One family member sharing such personal information can expose multiple generations on their family tree.

I've never uploaded my DNA to any open source database like GEDmatch and I wanted to see if I could still be identified from my anonymous DNA data. I reached out to CeCe Moore, a genetic genealogist who's solved many criminal cases. She guided me in the experiment. I would upload my 23andMe data anonymously to GEDmatch. CeCe would then send that anonymized file to Trostler, who would get to work trying to identify me. (Trostler and I had not previously met.) She also is a genetic genealogist and works primarily with adoptees, helping them solve such mysteries as the identity of birth parents.

Before sending Trostler my GEDmatch file, Moore learned that I'm pretty exposed when it comes to genetic information. My Aunt Catherine, an amateur genealogist, has uploaded her own DNA to GEDmatch, as well as data from my mother, grandmother, and cousin. "With your mom in there, it is a slam dunk," Moore told me. She suggested we make everyone's DNA except my cousin Jenn's private to better mimic what a genealogist might more typically encounter.

Moore sent Trostler my data on April 5. The

● Number of people who have sent a DNA sample to 23andMe and Ancestry:

>15m

next day, I received the following note in my Gmail inbox: “CeCe asked me to figure out who Gedmatch FU2936683 was. I found you!”

Using GEDmatch’s tools, Trostler started by pulling up a list of my DNA matches. The closest connection was my cousin Jenn. She then ran Jenn’s DNA matches, too, and quickly discovered which branch of her family tree to look at. I don’t share any DNA with Jenn’s dad, my uncle, who also had DNA in the GEDmatch database, which meant I was related to Jenn’s mother.

Trostler hit a roadblock when she searched the email address associated with Jenn’s account (actually my aunt’s email) on BeenVerified, a background check website. That briefly sent her barking up the wrong family tree; it turned out the email address also was listed in connection to a totally unrelated person. Googling the address helped Trostler figure out that it belonged to my Aunt Catherine, and that she was Jenn’s mother. Trostler then identified the names of my aunt’s parents. From there it was easy: She found an obituary for my grandfather, Raul Alcala, in the *Orange County Register*, which also listed the names of Aunt Catherine’s two siblings.

Next, Trostler turned to Facebook, landing on my uncle’s page. She guessed he didn’t have any children (he has one daughter). So the anonymous DNA, she figured, must belong to a child of Catherine’s sister, Nancy Alcala Brown. Trostler looked my mom up in the California Birth Index and found just one female child associated with a woman with the maiden name Alcala and last name Brown. It was me. Trostler Googled my name. When she saw my Bloomberg profile, along with the trove of articles I’ve written about DNA testing, she was sure she’d found the right person. “It’s not always that easy,” she says.

There were a few things that made my case simpler than most, she says. For starters, not only did I have a first cousin in GEDmatch, but thanks to the DNA of Jenn’s dad’s, the genealogist was able to quickly narrow her search. Also, my grandfather’s obituary dutifully listed all the names of his children. And my mom’s maiden name, Alcala, is a lot more unusual than Brown.

Trostler says typical cases take her at least 10 hours; others take as many as 30 hours or can’t be solved at all. But the growing popularity of DNA testing is speeding up her work. GEDmatch has about 1 million users, and that number will increase as some of the more than 15 million people who’ve sent their saliva to 23andMe and Ancestry upload their data there.

The majority of the human genome is the same from person to person. Variation adds as much as

about 0.1 percent of the total. It’s that variation that acts as a fingerprint, identifying who we are but also how closely related we are to another person. My next closest match in GEDmatch shared only a fraction of my DNA—69 centimorgans compared with the 830 centimorgans I share with Jenn.

As DNA databases grow, so too does the potential for abuse. “Misuse of surreptitious DNA is potentially a big problem,” says Debbie Kennett, genealogist and author. “You can imagine celebrities and politicians being stalked to get illicit DNA samples for paternity testing without consent.”

Today, a person interested in identifying someone from their DNA would require that person to somehow collect a vial of saliva and send it to a company like 23andMe. But in the future, technology accessible to law enforcement may become more widely accessible. Perhaps in the not-so-distant future, you’ll be able to swab your half-eaten ham sandwich in the work refrigerator and unmask the co-worker who ate your lunch. (It sounds ridiculous, but there’s already a company sequencing apartment complex dog poop to expose owners who don’t pick up after their pooches.)

Kennett also worries about people being charged for offenses they didn’t commit because their DNA was found at a crime scene, or about innocent people being subjected to intrusive social media and public-record searches as police try to identify a suspect. Recently, a woman in Washington state learned it was her DNA that led to a distant relative’s arrest in an Iowa murder when her name was disclosed in a search warrant.

Government DNA databases have rules governing access, but consumer DNA databases operate only according to a company’s terms of service. James Hazel, a researcher at the Center for Genetic Privacy and Identity in Community Settings at Vanderbilt University Medical Center in Nashville, recently suggested that a universal DNA database containing everyone’s information may do a better job protecting people’s privacy. With regulated access to a more limited set of genetic information than the data that can be culled from consumer testing reports, investigators could solve crimes without intruding as much on people who happen to be related to a suspect. “People who aren’t genealogists don’t realize how much information is out there about them,” Kennett says. “Even if they haven’t shared the information themselves, it’s likely that one of the relatives has shared private information.” —*Kristen V. Brown*

**“Misuse of surreptitious DNA is potentially a big problem”**

**THE BOTTOM LINE** The growing popularity of DNA testing is making the work of genetic genealogists faster and easier as an increasing number of people are making their genetic data public.

# NATURE HYDRATES



Did you know that each person needs

## 20-50 liters

of fresh water a day to meet their basic needs  
for drinking, cooking and cleaning?\*

By preserving and restoring essential lands upstream, we help strengthen the natural flow, filtration and regulation of watersheds that supply drinking water to people across Latin America, North America and Africa.

How can you help meet nature's needs? Learn by visiting [nature.org](https://www.nature.org).

The Nature  
Conservancy   
Protecting nature. Preserving life.®

\* World Water Assessment Programme (WWAP)



# Green, Rich, and Intimidating

● A climate movement backed by \$32 trillion in assets is pushing companies to change

A group of Royal Dutch Shell Plc executives sat in a conference room in the company's Hague headquarters in November. On the other side of the table were representatives for two small shareholders: the pensions board of the Church of England and Dutch fund manager Robeco Institutional Asset Management BV. The leaders of Europe's largest energy company realized that after months of argument, they'd lost.

The investors wanted Shell to make an abrupt

reversal on climate change. Only six months earlier, Chief Executive Officer Ben van Beurden had declared the company wouldn't set short-term targets on cutting carbon emissions, claiming they'd be little more than fodder for lawsuits. But unless the company changed course, it faced a public war with these shareholders. And while these two investors owned a small fraction of Shell's shares, they were backed by allies in Climate Action 100+, a coalition of some of the world's largest investors, who together manage \$32 trillion in assets.

In December, citing work with the little-known group, Shell announced near-term climate targets. A common theme was splattered across the headlines around the announcement: Shell had caved.

Two months later, BP Plc said it had agreed ►

## Too Big Not to Change

Companies identified by Climate Action 100+ as “systemically important emitters,” whose policies will be crucial to limiting global warming, by sector and market value\*

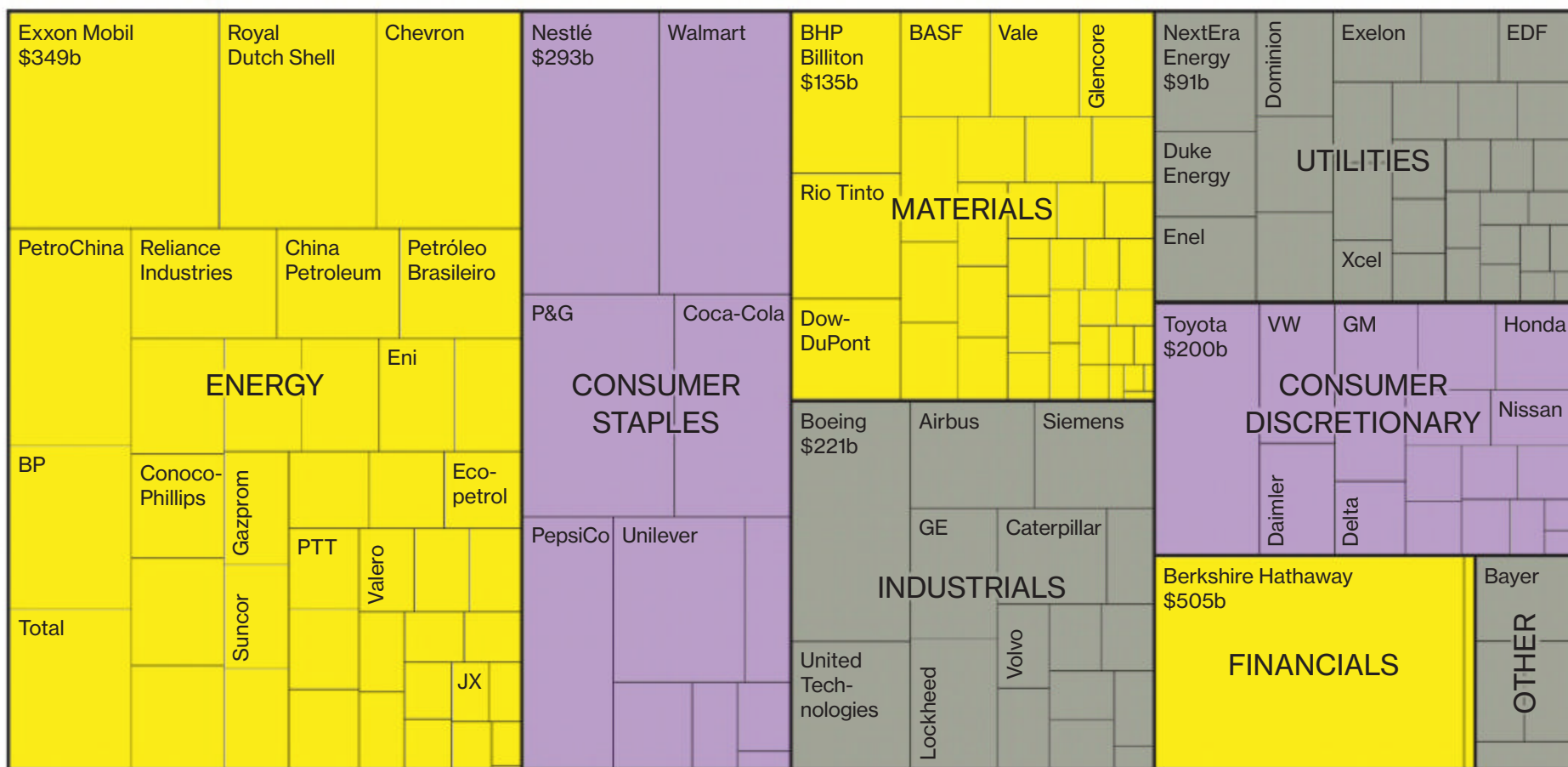

\*EXCLUDES THREE COMPANIES BECAUSE OF M&A ACTIVITY OR DELISTING; MARKET CAPS AS OF APRIL 5 CLOSE; DATA: CLIMATE ACTION 100+, BLOOMBERG

◀ to a shareholder resolution filed by Climate Action 100+ members and would release specific details about how its investments aligned with the Paris climate accord. Less than a month after that, Glencore Plc, a notoriously hard-nosed miner and trading house that’s one of the world’s largest suppliers of coal, said it would cap output of the fossil fuel because of global warming. It had also been paid a visit by Climate Action 100+.

This group of shareholders has become the biggest, richest, and possibly the most benevolent bully the corporate world has ever seen. What Climate Action 100+, or CA100+, wants is simple to understand and agonizing to achieve. It believes companies should detail exactly how climate change will affect their business, so shareholders can pull money from those that aren’t preparing for the future. (It asks companies to follow recommendations of the Task Force on Climate-related Financial Disclosures, which is chaired by Michael Bloomberg, the majority owner of Bloomberg LP, publisher of *Bloomberg Businessweek*.) It also wants companies to align capital spending decisions with efforts to limit global warming to less than 2C (3.6F). And it wants them to stop funding groups that lobby against those goals.

This idea is far from new, and dozens of groups—from the divestment movement to protesters climbing atop offshore oil rigs—have tried. The difference is that CA100+ isn’t out to slay corporate climate villains; it wants to help them succeed, albeit on different terms. The movement is working, and it’s growing. And it’s coming for everyone.

The first indications that something big was forming were in late 2015 in Paris. Anne Simpson, director of board governance and strategy in the investment office of the California Public Employees’ Retirement System, which manages the pensions of state workers, was headed there in preparation for the 21st United Nations climate summit. The French ambassador to the UN helped her invite about 20 of the largest institutional investors at the conference to a series of breakfasts, where together they started to formulate a plan.

The way fund managers were engaging with companies on climate change at the time was largely ad hoc. There were dozens of groups with overlapping missions. There was no unifying list of who should be targeted and what people should ask. “What we saw was the potential to focus on a relatively small number of companies, and if we

could partner with others, we actually could do something quite serious to move these companies along,” Simpson says.

Borrowing an idea from the financial crisis, the investor group found 100 companies they considered “systemically important emitters”—the too-big-to-fail institutions of the climate crisis. The largest of those was Warren Buffett’s conglomerate Berkshire Hathaway Inc.; the smallest was German elevator maker Thyssenkrupp AG. In December 2017, at the One Planet Summit in France, Climate Action 100+ made its first official appearance.

According to a person close to the Shell negotiations, who asked not to be identified because the discussions were private, when CA100+ showed up, executives were truly worried about a rift with the company’s largest investors. While CA100+ members mostly consider divestment a last resort, the threat looms large. For example, Legal & General Investment Management, one of Shell’s largest shareholders, dumped some of its holdings in Russian oil producer Rosneft PJSC and the U.S.’s Occidental Petroleum Corp. in June after the companies failed to engage with L&G on climate change.

Shell Chairman Chad Holliday is especially sensitive. He still bears the scars from environmental battles fought during his 39 years at DuPont, where he rose to CEO and chairman before leaving in 2009. In the 1970s the chemical manufacturer faced accusations that its products put a hole in the ozone layer and later became a major target of Greenpeace. In private, Holliday agreed with Shell CEO Van Beurden that the oil company needed to show it was on the right side of the climate issue.

When Shell announced its short-term goals, investor pressure immediately eased, while media reaction was so positive that employees of its Big Oil rivals made sniping comments about Shell to reporters. Behind the scenes, CA100+ members even asked an activist group called Follow This to stop embarrassing Shell with its climate-based shareholder resolutions. It did.

Shell will try to meet its climate targets partly by selling more natural gas: It burns less carbon than oil and generates more profit for the company. Representatives of CA100+ say they’re fine with any rationale companies use to make pledges. The group’s goal is to cut the financial risk associated with environmental catastrophe. The structure of the organization itself is loose, and progress is monitored mostly by two investors appointed to each company. The group includes 323 investors, and more are expected to join. CA100+ has had some setbacks: One big target, Exxon Mobil

Corp., successfully persuaded the U.S. Securities and Exchange Commission to block a resolution filed by members of the group. That was even after a member of the CA100+ steering committee helped put together a letter, signed by 114 investors managing \$9.5 trillion, asking the SEC to reject Exxon’s request.

Mark Lewis, head of sustainability research at BNP Paribas Asset Management, says the CA100+ logic means it may actually push a CEO to stop pursuing growth. Some companies, such as those specializing in carbon-heavy industries, are unlikely to successfully transition into a cleaner line of business and so will need to shrink over time, Lewis says. “You’ve never had a mobilization of investors on this scale before,” says Adam Matthews, who leads engagement for the Church of England pensions board. “For these companies, there’s no more hiding.” —*Kelly Gilblom*

**THE BOTTOM LINE** A coalition of large institutional investors is convinced that climate change isn’t just bad for the planet—it’s also bad for the bottom lines of companies that contribute to the problem.

## Investing in College Grads—Literally

● New financial instruments let students sell a share of their future earnings instead of borrowing

To pay for college, Amy Wroblewski sold a piece of her future. Every month, for eight and a half years, she must turn over a set percentage of her salary to investors. Today, about a year after graduation, Wroblewski makes \$50,000 a year as a higher-education recruiter in Winchester, Va. So the cut comes to \$279 a month, less than her car payment.

If the 23-year-old becomes a star in her field, she could pay twice as much. If she loses her job, she won’t have to pay anything, and investors will be out of luck until she finds work.

Wroblewski struck this unusual deal as an undergraduate at Purdue University, a public school in West Lafayette, Ind. To fund part of the cost of her degree in strategy and organizational management, she sidestepped the common source of money, a student loan. Instead, she agreed to hand over part of her future earnings through a new kind ▶

◀ of financial instrument called an income-share agreement, or ISA. In a sense, financiers are transforming student debtors into stock investments, with much of the same risk and—ideally—return.

In Wall Street terms, Wroblewski, a first-generation college graduate, is more small-company stock than Microsoft Corp. Her mother works as a waitress; her father, as a quality-control inspector in a car dealership's body shop. With a strong work ethic, Wroblewski always held down at least two part-time jobs in school, working as a Purdue teaching assistant, a Target cashier, and an Amazon seasonal worker. Showing potential for leadership—not to mention earnings—she rose to vice president of Delta Sigma Pi, a business fraternity.

Those qualities impressed a company called Vemo Education Inc., which vets students at Purdue and a handful of other schools on behalf of potential investors. More important, perhaps, Wroblewski believes in herself and her ability to make good on the contract. “Even with all my other loans, I knew I could make it work,” she says.

Americans owe \$1.5 trillion in higher-education debt, a burden that weighs down their dreams and the U.S. economy. The Federal Reserve says millennials are now less likely to buy homes than young people were in 2005, and even senior citizens find themselves still making payments on their student loans. Wall Street sees the crisis as an opportunity. College graduates on average earn \$1 million more over their lifetimes than those without a degree. Investors could capture some of that wage premium for themselves.

“I envision a whole new equity market for higher education in the next five years where today there's only debt,” says Chuck Trafton, who runs hedge fund FlowPoint Capital Partners, which has invested in ISAs, including Purdue's. ISA experts say they have fielded calls from some of the world's largest investment managers that are considering investing in the contracts. And Tony James, executive vice chairman of money manager Blackstone Group LP, formed the Education Finance Institute to help schools study and develop ISAs.

For now, the market for income-share agreements can be measured in the tens of millions of dollars, a tiny sum compared with the \$170 billion in outstanding asset-backed securities created from student loans. Only some schools let outside investment firms buy a stake in students. Others seek out individual donors, mostly wealthy alumni, or use money from their own endowments.

Along with Purdue, which started its program in 2016, some smaller private schools such as Lackawanna College in Scranton, Pa., and Norwich

University in Vermont are offering ISAs. The University of Utah recently announced a pilot plan.

ISAs raise all kinds of questions. How many students will lose their jobs and be unable to pay? How much should Wall Street demand as compensation for the risk? Investors typically ask for a smaller slice from students with more lucrative majors. At Purdue, for example, English majors borrowing \$10,000 pay 4.52 percent of their future income over almost 10 years; chemical engineers, 2.57 percent in a bit over seven years.

Purdue set up its program to be competitive with many student loans for the typical borrower. Consider a junior economics major who needs \$10,000. Through a private loan, she'd likely pay about \$146 a month, or \$17,576 over the course of 10 years. Through an ISA, a student with a starting salary of \$47,000, Purdue's estimate for its 2020 economics graduates, would pay a total of \$15,673, assuming 3.8 percent annual salary increases. That would be a good deal. But, if she found a \$60,000-a-year job, she'd have to fork over \$20,010.

Financial firms and for-profit colleges have been known to prey on college students' financial naiveté to sell them high-priced private student loans rather than steer them toward more favorable government-backed ones. While schools offering ISAs say they will offer them only after government loans with the most favorable terms have been exhausted, some students may end up again with regrets.

“There's a level of enthusiasm that's overstated,” says Julie Margetta Morgan, a fellow who studies higher education at the Roosevelt Institute, a think tank focused on reducing income inequality. “It's pretty darn near impossible to say whether an ISA is better or worse for an individual.” Morgan dislikes that ISAs require arbitration, which means students give up their right to sue in court.

The last big ISA experiment—at Yale in the 1970s—ended up as a cautionary tale. The university pooled all borrowers, and they owed the

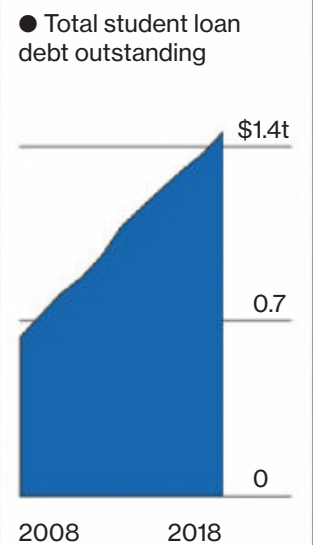

### The Price Tag on Your Passion

Estimated payment schedule for a \$10,000 income-share agreement made through Purdue University in a student's senior year, by major

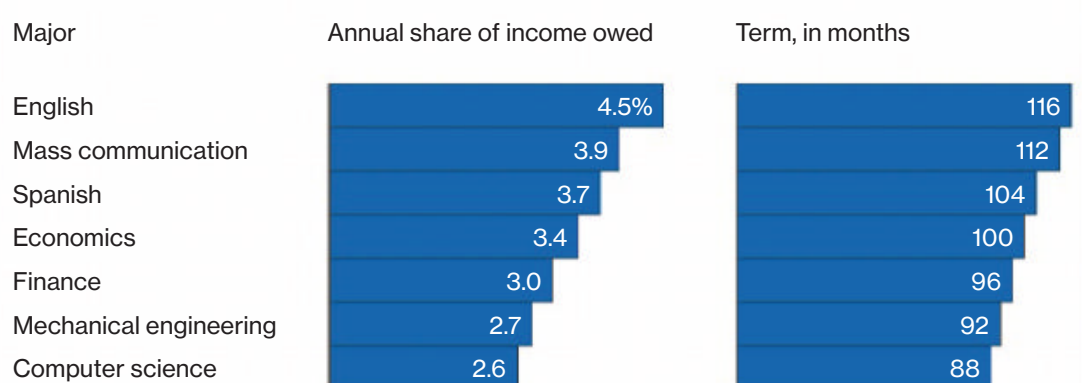



school a percentage of their incomes for 35 years, or until everyone paid back what they owed. The idea was that graduates who ended up with high-paying jobs in finance would subsidize those who chose public service.

But many students defaulted, leaving the remaining borrowers on the hook longer than they'd anticipated. Some wealthier students exited the pools via large, one-time buyout payments. The remaining students tended to be lower-income. Some stopped paying altogether. Yale ultimately bailed out the borrowers, winding down the program in 2001.

Juan Leon, who sells business jets for Dassault Aviation, graduated from Yale in 1974 with a degree in urban studies. He borrowed \$1,500 through the college's Tuition Postponement Option. By the late 1990s, he'd paid back \$8,000. "We didn't read the fine print," Leon says. "It was quite, quite onerous."

Students have more protection under newer plans. Purdue, for example, caps total payments at 2.5 times what a student borrowed, so the most successful don't feel gouged. And students making less than \$20,000 a year won't be charged at all, as long as they are working full time or seeking work. Those who are working part time or not seeking work will have their payments deferred, which means they'll owe for a longer period of time.

Purdue has arranged more than 700 contracts worth \$9.5 million and closed two investment funds totaling \$17 million. David Cooper, Purdue's chief investment officer, helped to develop the program and pitch it to investors after almost a decade of overseeing investments for Indiana's retirement

system. He says the funds are drawing more interest now that the oldest contracts have more than 20 months of repayment data. "We feel like we've got the pricing for the students at a pretty good spot," Cooper says. "At the same time, it's a reasonable return for the investors."

Purdue's early funds attracted investments from wealthy individuals, as well as nonprofit Strada Education Network and INvestEd, a nonprofit lender and financial literacy organization in Indiana. Cooper says ISAs may make most sense for socially conscious investors, but he points out that even funds seeking lofty profits might one day be interested if they can juice returns with leverage.

Charlotte Hebert, 23, who graduated from Purdue in 2017, has mixed feelings about the \$27,000 she took out from an ISA to pay for her senior-year costs. A professional writing major, she's required to shell out 10 percent of her income for the term of the deal. That's about 2.5 percentage points more than an engineer would pay. The daughter of a teacher and a nurse, she makes about \$38,000 a year as a technical writer for an engineering firm in Lafayette, Ind.

She pays investors \$312 a month. "I don't think it's the perfect solution," Hebert says. "I am of the opinion that in a society where most of its workers need a college education, nobody should be paying this much to be what is considered a functional member of society." —*Claire Boston*

**THE BOTTOM LINE** The latest idea for financing college is to turn students into something like an equity investment—the more they earn, the more an investor can get paid.

▲ Wroblewski



## Season Of Doubt

● Farmers' support for Trump's trade wars is being tested by the loss of export markets

Sean Gilbert surveys a two-year-old apple tree that's head-high, a half-dozen branches growing off it at right angles. With the other trees planted at 3-foot intervals alongside, it's part of what he hopes will be before long a lucrative wall of fruit.

If Gilbert lets nature take its course, the tree and thousands like it planted on this 20-acre orchard in Yakima, Wash., later this year will bear the first crop of Cosmic Crisp, which he and other growers in the state are calling a new blockbuster apple. If instead he chooses to interrupt the fruiting, he'll be letting the tree reinvest its energy—think of it as the horticultural equivalent of compounding interest—into growing bigger and stronger faster, which may mean more fruit in the long term.

It's a consequential decision: Gilbert Orchards has invested about \$900,000 into the single Cosmic Crisp plot on which he's standing. For the 122-year-old family business, Gilbert says, that amounts to a "big bet." The gamble is all the more risky because growers like him have no experience with this cultivar. Everyone agrees that the cherry red, slightly tart, ever-so-juicy Cosmic Crisp is a good apple for eating, he says, and stays fresh as long as a year in storage. "Everything else is just guessing."

For Gilbert Orchards, whose products wind up in fruit bowls as far away as India and Taiwan, the decision on whether to delay the first harvest of Cosmic Crisps is complicated by the uncertainty bred by Donald Trump's trade wars. Mexico and China have hiked duties on U.S. apple imports in response to Trump's policies. India has threatened to follow suit.

Across Washington state's apple orchards, growers' exports have fallen almost 30 percent since last spring. "We've been through these kinds of things before, but not with as many markets," says Mark Powers, president of the Northwest Horticultural Council. "It's not like we can divert the millions of cartons that are going to India to Costa Rica."



Spring is supposed to be a time of optimism in rural communities across America. It's when farmers sow the seeds of prosperity into neat, GPS-calibrated rows and when they pray for just the right amount of rain and sun and for prices to hold up so that when fall approaches, there's a crop worth harvesting. This year is different. In Washington apple orchards, North Carolina hog farms, and soybean fields along the Mississippi River Basin, the season is filled with doubt. After taking a hit to their bottom line in 2018 of the sort that some say they haven't seen since the 1980s, farmers are hoping for a return to normalcy.

Trump's determination to upend the global trading system comes at an inconvenient time for one of the nation's premier export industries. No country has mastered the science of the ever-increasing yield quite like the U.S. has. It's the



world's leading producer of commodity crops such as soybeans and corn and a major source of apples, beef, pork, and wheat. Agriculture has also been an important backer of successive administrations' push to seal trade agreements around the world. Pacts such as the North American Free Trade Agreement have spurred agricultural exports, which have grown 170 percent over the past 20 years.

Yet U.S. farm profits have been shrinking since they peaked six years ago, amounting last year to roughly half what they were in 2013. As a result of successive years of bumper crops, prices for key commodities like soybeans and corn are about 40 percent lower than they were in 2013. At the same time, farmers have had to contend with the administration's crackdown on immigration, which deprives them of migrant labor, and climate change, which

most recently took the form of historic floods that devastated Midwestern agricultural states.

The trade wars have come on top of all that. In the year since the Trump administration launched its tariff offensive, the country's trade partners have retaliated by hiking duties on apples, cherries, ginseng, sorghum, and soybeans, to name a few crops. It's a familiar pattern: American farmers have long borne the cost for protectionist policies pushed by the country's industrialists. The 1828 "tariff of abominations" designed to safeguard Northern manufacturers from an influx of lower-priced imports from Britain was opposed stridently in the agrarian South. It led to a political crisis that dogged Andrew Jackson's presidency and precipitated South Carolina's first threats of secession.

Conscious of the support he garnered in farm states in the 2016 election and the costs they've ►

▲ Gilbert inspects a Cosmic Crisp tree on his orchard in Yakima

## Ups and Downs on the Farm

U.S. agricultural exports

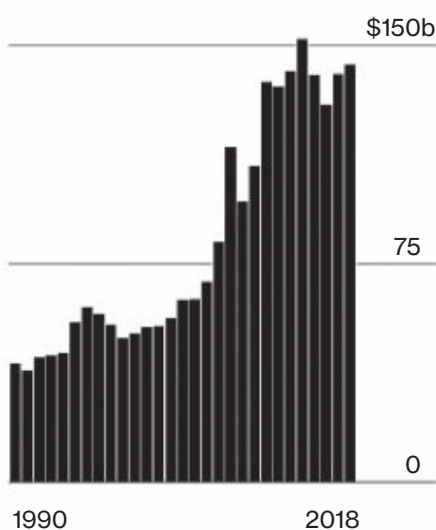

Net farm income

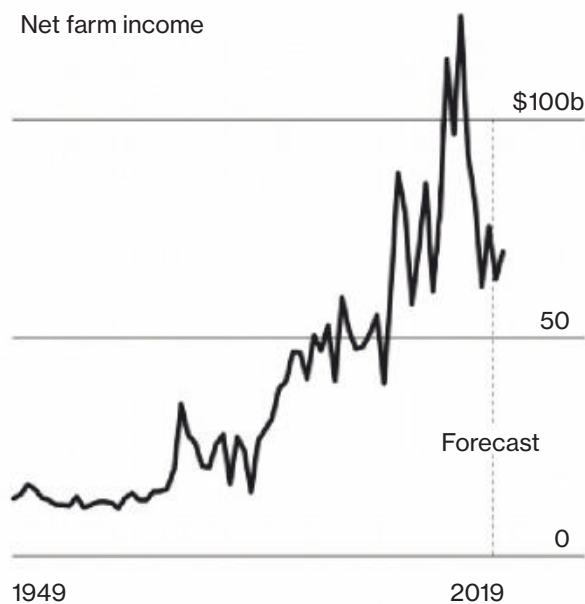

Exports over \$100m, 2017\*

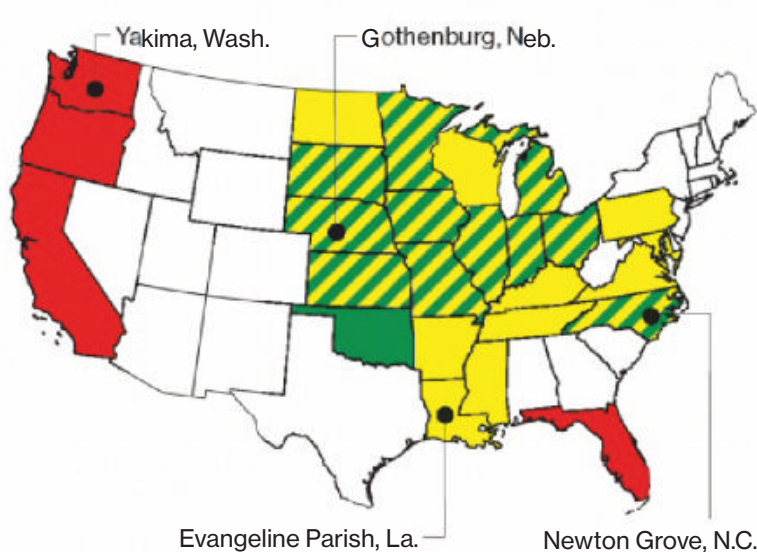

◀ been bearing, the president last year announced an aid program of as much as \$12 billion to cushion their losses. He's also promised his trade wars will eventually be a boon for the U.S. agricultural economy, whether because of additional Chinese purchases of soybeans and other commodities or the further opening of vital markets such as Japan. "We're doing trade deals that are going to get you so much business, you're not even going to believe it," he told a cheering crowd at the American Farm Bureau Federation's annual meeting in New Orleans in January. "Your problem will be: What do we do? We need more acreage immediately. We got to plant."

Still, plenty of people in farm country are fed up with a fight that's only adding to the widening economic gulf between rural and urban America. "Why should just a few good patriots take it on the chin for the whole of the country?" asks Larry Wooten, the outspoken president of the North Carolina Farm Bureau.

Economists are still trying to quantify the impact of Trump's pugnacious protectionism on agriculture. One study by researchers at Iowa State University estimated the various tit-for-tat tariffs imposed in 2018 would cost the farm state as much as \$2 billion in lost economic activity, much of it in its corn and pork industries.

Calculating the drop in export revenue or the collapse in prices for some commodities isn't difficult, but it's harder to pin numbers on other economic consequences, such as stalled investment. Travel through farm country, and it's hard to find a farmer who doesn't have a story about the combine not bought or the orchard not planted.

Gilbert's business, which employs the equivalent of 800 people full time and counts big-box retailers

such as Walmart Inc. and Costco Wholesale Corp. as domestic customers, has been hit hard by the trade wars. The operation typically exports a third of its production, according to Gilbert, but shipments from the most recent harvest are down 25 percent from the previous year.

Trump's trade wars haven't crimped only Gilbert's revenue; they've also eaten into his future profits. Instead of replanting 180 acres of the 2,000 or so he manages with new varieties like the Cosmic Crisp that fetch premium prices, he scaled back his plans last year to 120 acres.

Talk to people in Washington's apple industry, and they mention the Cosmic Crisp alongside the Granny Smith and the Red Delicious as a revolutionary variety two decades in the making. A product of Washington State University (WSU)'s crossbreeding program, it's a singularly crunchy apple whose flesh doesn't brown after it's cut. The variety is also robust enough to ship to far-off lands.

Growers in Washington state will have exclusive rights to the Cosmic Crisp until 2027. But Lynnell Brandt, whom WSU hired to manage its commercialization, already has world apple domination in mind. Anticipating success in China, he's cut a licensing deal with a grower on the mainland, a move he hopes will deter intellectual-property thieves there.

The stakes are high. With the cost of planting orchards as much as \$60,000 an acre, "people are taking huge risks to try and get into a fruit that they hope will get them an adequate return," Brandt says.

Many growers say they have no choice: Labor and other costs have been rising steadily for apple farms, even as consumers have slowly soured on industry stalwarts such as Red Delicious and Galas, which together made up about half of Washington's crop of 120 million boxes last year,

● Apple production in Washington state, boxes  
■ Share exported

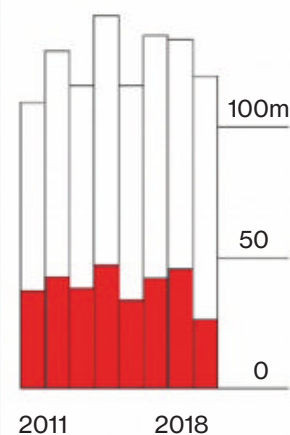

according to the Washington Apple Commission. The U.S. domestic market for Washington apples has been static for years, at about 90 million boxes. That puts a premium on developing new export markets and selling higher-margin varieties at home. Honeycrisps fetch as much as \$70 a box, more than three times the price of Red Delicious.

But in apple orchards this spring, it's easy to find signs that the trade wars are delaying the transition of an industry that's been dominated by family-owned operations and is only starting to open up to outside capital. "You are not seeing the sort of investment in orchards or planting equipment that you would normally see," says Powers, head of the Northwest Horticultural Council.

Nature may still wield more power to disrupt farmers' lives than tariffs. The Iowa Farm Bureau has estimated that losses from recent flooding along the Missouri River, as well as potential flooding from local rainfall and snowmelt in states to the north, could cause more than \$2 billion in damage in the state.

At Andy Jobman's farm in central Nebraska, the Platte River, a tributary of the Missouri, overflowed its banks last month, leaving some fields under as much as 8 feet of water. When the flood waters receded, they left behind muddy debris that needed to be carted away and a host of delayed tasks—from applying fertilizer to tilling—to prepare the fields for new crops.

Jobman, who farms 1,200 acres of soybeans and corn with his father and brother, can't escape the persistent uncertainty caused by the trade wars. Because of the collapse in demand for soybeans last year, his family stored some of the harvest. Aid payments doled out by the U.S. Department of Agriculture have helped plug the revenue hole, but most financial decision-making has "slowed down," he says, because it's hard to get a bead on where prices are headed.

One open question is whether business will revert to normal if tariffs are lifted. History has shown that even a short interruption in the supply of a commodity can have long-term consequences for American farmers. A U.S. trade spat with Japan in the 1980s that lasted only days helped trigger an increase of investment in Brazil's soybean sector, now the biggest U.S. competitor for that crop. China's punitive tariffs on U.S. soybean imports have prompted pig farmers on the mainland to find alternative sources of feed, says Veronica Nigh, an economist at the American Farm Bureau Federation. It's not clear whether they'll ever resume purchases on the same scale, even if Beijing commits to buying more U.S. soybeans as part of a trade deal.

Daniel Kowalski, a vice president of agricultural lender CoBank ACB, worries that one of the most enduring effects of the trade war may be the expansion in crop production from South America to the Black Sea "to fill space we vacated." The reality is that, under Trump, the U.S. has so far been losing more access to lucrative agricultural export markets than it's been gaining. The president's withdrawal from the 12-nation Trans-Pacific Partnership immediately after he took office left U.S. beef and pork producers at a disadvantage in Japan, as well as in fast-growing economies such as Vietnam, vs. competitors in Australia and New Zealand, which remain in the TPP. European Union farmers are also benefiting from a trade pact with Japan that went into effect on Feb. 1.

The fight with China has hurt American soybean growers and other agricultural exporters. But so have Canada's and Mexico's retaliation against Trump's steel tariffs. That's the big reason Chuck Grassley, the powerful Iowa Republican who heads the Senate Finance Committee, has said duties on Canadian and Mexican steel will have to be lifted before Congress ratifies the United States-Mexico-Canada Agreement, Trump's replacement for Nafta.

Meanwhile, the productivity of America's farm and livestock sectors keeps climbing, generating even greater food surpluses that will continue to depress prices if buyers can't be found overseas. "Keeping farmers and agribusinesses healthy ▶

● U.S. soybean inventories in metric tons

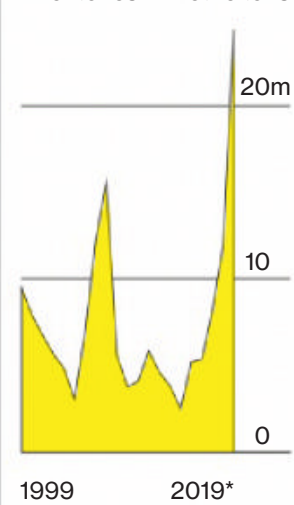

▼ Fontenot amid the grain bins on his farm in Ville Platte





◀ becomes more challenging if we can't grow the export markets like we have in the past," CoBank's Kowalski says.

In Ville Platte, La., Richard Fontenot tills land his family has tended for five generations. The souring of the export relationship with China last year cost him \$300,000 in the form of 1,000 acres of soybeans he was forced to leave in the field to rot because the grain bins on his property were already full, as were the export-driven elevators he sells to. Insurance covered some of the losses, but when he tried to tap into the aid the Trump administration made available for farmers hurt by the trade wars, he was told he wasn't eligible because he hadn't harvested the crop. So there's been belt-tightening. Instead of shelling out \$300,000 for a used combine as planned, Fontenot spent \$30,000 to rehab his existing machine. "I had a crop in the field that I couldn't export because of the tariffs," he says.

Fontenot, who like many farmers in what's known as the Cajun Prairie raises rice and crawfish alongside his soybeans, is keeping a wary eye on a near-record stockpile of soybeans nationally and on the Mississippi's high waters. He remains a Trump supporter, as are most voters in Evangeline Parish, where the president won almost 70 percent of the vote in 2016. His hope is that the losses he's taken on soybeans will be salvaged by future rice sales to China. "He's costing me money today, but I think he's going to make me money in the future," Fontenot says.

Trump's tariffs—and the effect they're having on investment—are hurting business at Hog Slat, the 50-year-old family business David Herring runs with his brother in the North Carolina hamlet of Newton Grove, where their grandfather's hardware store once stood. Hog Slat makes everything it takes to build the vast sheds that house pigs, from the slotted floors that gave the business its name to feed bins and ventilation systems. It also assembles the sheds. Over the past year, its business has slowed.

There have been other blows, too. Steel tariffs raised the price of the domestic metal the company uses. Herring's own hog business was hit by the retaliatory duties imposed by Mexico, the biggest export market for U.S. pork by volume, and the resulting collapse in prices. Hog Slat is a private company, and Herring, who earlier this year assumed the rotating presidency of the National Pork Producers Council, won't disclose its financials, saying only that "there was a lot of money lost" and he had to lay off 80 of his 1,500 employees in the U.S.

In a community where conservatism is the rule, farmers remain optimistic that the president they voted for in 2016 will live up to his pledge to make it up to farmers, Herring says. It helps that they've benefited from Trump's deregulatory agenda, including laxer federal rules for water use, as well as cuts to business and estate taxes. But "patience is not where it was six months ago," he says. And that forbearance may not survive another year like the last.

For Lorenda Overman, 2018 was the worst year she's seen in the 37 since she married a farmer and moved onto the patch of North Carolina that her husband's family has owned and nurtured since before the Revolutionary War. There was the economic storm that came in the form of the trade wars, and then there was Hurricane Florence, which turned harvest time into a scramble to salvage crops. For the first time, the Overmans had to delay writing the monthly checks that support the families of two of their grown children, who live and work alongside them on the farm. "You are taking the food right out of the mouths of your grandchildren," she says.

Now she's worried about numbers that don't pencil out even before some crops have been planted. At current prices, this year's corn, wheat, and soybeans are set to yield almost \$290,000 in losses, by her calculations. And that's if nothing else goes wrong. But she hasn't lost hope in Trump. If the man whom she voted for and cheered from the sixth row at the Farm Bureau convention cuts a deal with China, she hopes markets will respond. "A swipe of the pen, and those prices can bounce back," she says.

Some of the changes brought on by Trump's trade offensive may linger, though. The 7,500 hogs that spend 18 weeks at a time housed in six sheds on the Overmans' farm in Goldsboro are owned by what's known in the industry as an "integrator." To fatten them up from 10-week-old piglets into 250-pound to 300-pound beasts, the family is paid a set rate that hasn't changed in a decade. But in part because of trade war losses, the integrator will be phasing out its multiyear contracts and replacing them with 120-day ones, a switch that will leave the family more exposed to the vagaries of the markets. The change won't happen till 2021. Overman hopes the family business can stick it out until then. "I'm praying every night," she says, "that we are not in the same place we are a year from now." —Shawn Donnan and Shruti Singh

THE BOTTOM LINE Trump's trade wars are likely to leave economic scars for American farmers. Still, many continue to hope Trump's moves against China and other countries may pay off.

◀ Overman at her hog farm in Goldsboro

● U.S. boxed pork spot prices, per hundredweight

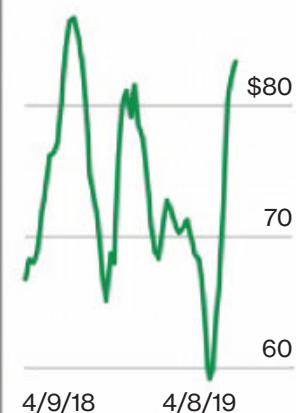

5

POLITICS

# The Real Tax Winner:



## The Millionaire CEO

Cutting the top marginal rate was always going to benefit the wealthy most

By the time you read this, most Americans will have already filed their first returns under the 2017 Tax Cuts and Jobs Act. A Reuters/Ipsos poll last month said a majority of them think the new law didn't save them a dime, but they're wrong: The Urban-Brookings Tax Policy Center estimates that average Americans saw a 1.8 percentage point reduction in their effective tax rate. The actual effect—an average savings of \$1,610—was simply so slight and so spread out that they didn't notice.

The rich noticed. The top 1 percent of income

earners saved 2.3 percentage points, according to Urban-Brookings, or \$51,140. The top 0.1 percent, who make more than \$3.4 million a year, saved the same amount in percentage terms as the average Joe, but in dollar terms made out with \$193,380.

There's a particular type of rich person, probably living somewhere in Florida, Texas, or another low-tax state, who did even better. This person runs his own company or companies, likely in the real estate business. Because men run about 80 percent of businesses in the U.S., this person

is probably male. Sure, he cares about individual income tax rates, but he doesn't make most of his money as a wage earner. He's an owner.

The first tax break he probably spotted was the decline in his marginal tax rate, from 39.6 percent on every dollar above \$470,700 to 37 percent past \$600,000 if he's married and filing jointly. That's not the most important cut he received by any stretch—he makes too much money elsewhere—but it's the one most Americans understand.

He got his first windfall from the new tax law back in 2017, before it even passed. As Republicans floated their proposal for a massive cut to the corporate tax rate, from 35 percent to 21 percent, investors began buying corporate shares in anticipation of its passing, says Todd Castagno, an analyst for Morgan Stanley. "Ultimately, investing in stocks is buying future earnings," he says, and lower taxes mean better quarterly numbers.

In a report released last year, Morgan Stanley estimated the tax bill bolstered the stock market by 8 percent to 10 percent. "Corporate shareholders made out like bandits," says Steven Rosenthal, senior fellow at the Tax Policy Center. Take investor and Berkshire Hathaway Inc. Chief Executive Officer Warren Buffett: In last year's annual letter to shareholders, he reported that in 2017, Berkshire's shareholder equity grew by \$65.3 billion, to \$348.3 billion.

Our hypothetical rich person's businesses are probably in commercial real estate. Those are most often structured as pass-throughs, such as LLCs or other partnerships, which are taxed not at the corporate level but at their owners' marginal tax rate, and the new law lets their owners shield 20 percent of their business income from any taxes at all. This deduction was intended to benefit small businesses. Congress blocked high-income owners of some service providers from taking the break in most cases, including lawyers, doctors, and athletes. But lawmakers gave it to commercial real estate developers regardless of income.

Real estate dodged other bullets, too. For most businesses, Congress killed so-called like-kind exchanges, which let sellers of certain property such as machinery or artwork avoid capital-gains taxes so long as they reinvested the proceeds in similar property. But the provision was preserved for real estate. If our rich person invests in property in a "qualified opportunity zone," a designation created by the new tax law to encourage investment in low-income areas, he'll be able to avoid some capital-gains taxes and defer the rest for years. Many opportunity zones are indeed in low-income areas, but others include fast-gentrifying neighborhoods such as Long Island

City in Queens, N.Y., where the developer stands to make a much larger return.

Our wealthy developer has likely already called his estate planner and received welcome news: His heirs will get to keep more than \$4 million extra when he dies. That's because the law roughly doubled the amount of his estate that's tax-exempt, raising it to \$22.8 million in 2019 for a couple; because the estate tax rate is 40 percent, that's \$4.56 million now going straight to the kids. The exemption reverts to the lower level at the end of 2025, but our rich person won't need to die by then for his estate to benefit from the higher limit, says Mitchell Gans, a tax law professor at Hofstra University Law School. That's because the lifetime ceiling on tax-free gifts is set at the same level as that of the estate tax exemption. When a wealthy individual makes a large gift, it's counted against the exemption when he dies. Even though the estate tax limit is scheduled to fall by 2026, as long as he makes the gifts by then, Gans says, the Internal Revenue Service likely won't penalize him if his largesse exceeds the lower limit. The merely rich person whose estate totals less than \$22 million will of course have to hold on to some money to live on. "It's going to be so much easier for the super-wealthy than the modestly wealthy," says Gans.

While Congress's Joint Committee on Taxation and think tanks such as the Tax Foundation and Tax Policy Center continue to generate estimates about how much each type of taxpayer will gain from the law, the true size of the benefits might not be apparent for years, as tax attorneys delve deep to find loopholes for their clients—attorneys such as Jonathan Blattmachr.

Blattmachr, who's now mostly retired, is like Neo in *The Matrix*: He can bend or get around rules to save clients potentially millions of dollars. "For a lot of accountants, the law has been a real god-send," he says, precisely because it's so complicated. Take state and local income and property taxes. The new law capped the amount of those that Americans can deduct from their federal taxes at \$10,000 a year—that's why the tax winner probably lives in or is planning to move to a low- or no-tax state such as Texas or Florida, where the state and local tax (SALT) cap matters less.

The summer after the law passed, Blattmachr recommended to his wealthy clients that they split the ownership interests in their properties among several Alaskan non-grantor trusts that could let them avoid the cap. Non-grantor trusts are treated as individual taxpayers, so each one could potentially take advantage of the \$10,000 SALT deduction; in a no-tax state such as Alaska, that would ►



● Mnuchin

● Average savings under the 2017 tax law by those in the top 0.1 percent

**\$193k**



◀ go extra far. Confused? Don't think your storefront tax preparer or downloaded software would have come up with that? For sophisticated tax lawyers like Blattmachr, that's the point.

It wasn't the point for Treasury Secretary Steven Mnuchin, or at least so he said in an interview on CNBC shortly after Donald Trump was elected president. Any reduction in the highest tax rates would be offset by loopholes and deductions that would be closed or eliminated, he promised, resulting in no absolute tax cut for the wealthy. During his confirmation hearing before the Senate Finance Committee, Oregon Senator Ron Wyden, the panel's top Democrat, dubbed this the Mnuchin Rule.

That wasn't going to work, tax attorney Dana Trier remembers thinking while watching the hearing on TV. Trier previously worked on tax issues at the Treasury Department for Presidents Ronald Reagan and George H.W. Bush. The summer after Mnuchin was confirmed, the department hired Trier as deputy assistant secretary for tax policy to help write the new law.

As Trump's signature legislative achievement made its way through Congress, Mnuchin asked his staff to run the numbers over and over, reacting with disappointment every time they showed a huge benefit for the wealthy, says Trier, who left the government in February 2018. "I personally don't think he was the most competent tax policy leader in the world," he says of Mnuchin. "But the one thing for sure is he was not out to benefit the rich."

If that's the case, he failed completely. "At the end of the day, when your central policy calls for lowering maximum rates, it's not going to be easy not to benefit rich people," says Trier. "It's just a fact." He says the IRS will surely stamp out, or at least deter, gamesmanship of the law—it's already issued guidance to try to eliminate the Alaskan Trust loophole, which Blattmachr acknowledges. But Trier also says that 20 percent to 25 percent of the unintended loopholes the IRS kills will end up surviving court challenges that will likely play out over the course of years.

In a statement, a Treasury spokeswoman said the 2017 tax law "cut taxes across the board, with the particular aim of providing relief for hard-working, middle-income families." She added that aspects of the new law, including the doubling of the standard deduction and an "enhanced" child tax credit, helped low- and middle-income Americans in particular.

It's not lost on Trier that the winner of the 2017 law probably looks a lot like President Trump. That wasn't on purpose, he says, adding that he thinks

the law still did many things that helped American growth and competitiveness. "I detected a lot of intelligent, well-meaning people making mistakes," he says. "Maybe you don't believe this, but I didn't detect people trying to help out specific lobbyists a whole lot."

The idea that the White House engineered it all? "I think that's crazy," Trier says. "The president and his team in honesty did not have the sophistication and competence to lead this legislative effort. That's the reality here." —*Joe Light*

THE BOTTOM LINE Mnuchin and others in the Trump administration pledged that the tax law wouldn't benefit the wealthy, but that promise was doomed from the start.

## We the People Are Bad at This

● Democracy itself isn't the problem. It's how we go about it

The Brexit disaster has stained the reputation of direct democracy. The United Kingdom's trauma began in 2016, when then-Prime Minister David Cameron miscalculated that he could strengthen Britain's attachment to the European Union by calling a referendum on it. The Leave campaign made unkeepable promises about Brexit's benefits. Voters spent little time studying the facts because there was a vanishingly small chance that any given vote would make the difference by breaking a tie. Leave won—and Google searches for "What is the EU" spiked *after* the polls closed.

Brexit is only one manifestation of a global problem. Citizens want elected officials to be as responsive as Uber drivers, but they don't always take their own responsibilities seriously. This problem isn't new. America's Founding Fathers worried that democracy would devolve into mob rule; the word "democracy" appears nowhere in the Declaration of Independence or the Constitution.

While fears about democratic dysfunction are understandable, there are ways to make voters into real participants in the democratic process without giving in to mobocracy. Instead of referendums, which often become lightning rods for extremism, political scientists say it's better to make voters think like jurors, whose decisions affect the lives and fortunes of others.

**In 2013, candidates for mayor of Minneapolis linked arms and sang *Kumbaya***

Guided deliberation, also known as deliberative democracy, is one way to achieve that. Ireland used it in 2016 and 2017 to help decide whether to repeal a constitutional amendment that banned abortion in most cases. A 99-person Citizens' Assembly was selected to mirror the Irish population. It met over five weekends to evaluate input from lawyers and obstetricians, pro-life and pro-choice groups, and more than 13,000 written submissions from the public, guided by a chairperson from the Irish supreme court. Together they concluded that the legislature should have the power to allow abortion under a broader set of conditions, a recommendation that voters approved in a 2018 referendum; abortion in Ireland became legal in January 2019.

Done right, deliberative democracy brings out the best in citizens. "My experience shows that some of the most polarising issues can be tackled in this manner," Louise Caldwell, an Irish assembly member, wrote in a column for the *Guardian* in January. India's village assemblies, which involve all the adults in local decision-making, are a form of deliberative democracy on a grand scale. A March article in the journal *Science* says that "evidence from places such as Colombia, Belgium, Northern Ireland, and Bosnia shows that properly structured deliberation can promote recognition, understanding, and learning." Even French President Emmanuel Macron has used it, convening a three-month "great debate" to solicit the public's views on some of the issues raised by the sometimes-violent Yellow Vest movement. On April 8, Prime Minister Edouard Philippe presented one key finding: The French have "zero tolerance" for new taxes.

Another way to fix democracy is to change how people vote. Rather than have voters register a simple yes or no for a candidate, there's growing interest in ranked choice voting, which allows them to express their full range of preferences. Voters rank everyone on the ballot, and if no one wins a majority of first-place votes, the candidate who got the fewest is dropped from consideration and his or her votes are redistributed to the other candidates based on voters' second choices. This winnowing process is repeated until someone wins a majority.

The goal is to elect candidates who are acceptable to a broad swath of the electorate. Those in the running take care not to offend each other's supporters. Australia has used ranked choice voting in national elections for a century. In 2018, Maine became the first U.S. state to use it for federal offices; San Francisco and Minneapolis, among others, use it for municipal elections. In 2013 candidates for mayor of

### How Ranked Choice Voting Works

The candidate most people like—not love, necessarily—comes out on top

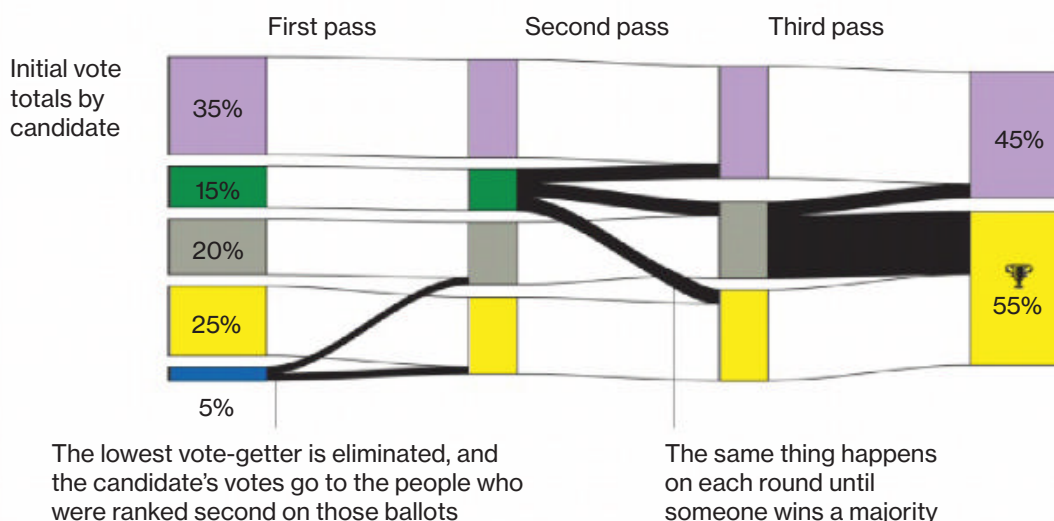

Minneapolis linked arms after their last debate and sang *Kumbaya*. (Seriously.)

The U.S. Constitution's framers tried to insulate government from mob rule by having senators elected by state legislatures and the president by members of an electoral college, who weren't originally required to echo their states' voters. Democracy gradually became more direct, with a surge in the early 20th century, when the Progressive movement brought women's suffrage, direct election of senators, and a wave of state laws providing for referendums, ballot initiatives, and the like.

What the American system needs now is a third stage of development, journalist Nathan Gardels and investor Nicolas Berggruen argue in *Renovating Democracy: Governing in the Age of Globalization and Digital Capitalism*, a book coming out on April 30. In 2010 they founded the Think Long Committee, a bipartisan group working toward improving governance in California. In 2014, then-Governor Jerry Brown signed a Think Long-backed measure requiring public hearings on ballot initiatives. The new process led to a first-in-the-nation digital privacy act last year.

Democracy tends to work best at the local level, where people can engage face-to-face on issues that affect them directly. Thomas Jefferson wanted to place most functions in "ward republics" of a few hundred citizens. That's not realistic today, if it ever was. But Jefferson's desire to involve everyone remains relevant. Last year, Yale political scientist Hélène Landemore advised the French National Assembly on how to involve the public. She quoted the American civil rights leader W.E.B. DuBois: "We must appeal not to the few, not to some souls, but to all." —Peter Coy

THE BOTTOM LINE Individuals participating in democracy need to feel some kind of stake in the outcome of their decisions—not only for their own sake but also for that of their countries.



# 5280 feet

# to prove yourself

**Square Mile Relay returns to  
New York City on May 2nd.**

**One team. Ten runners. One mile each.**

Race corporate rivals in a one-of-a-kind,  
immersive team-building experience.

Learn more and register your team at  
[squaremilerelay.com/NYC](https://squaremilerelay.com/NYC)

**#WeRunThisCity**



Bloomberg  
**SQUARE  
MILE  
RELAY**  
**NEW YORK**

# Retirement

## The 'Don't Ask' Conversation

Concerned about the baby boomer brain drain, employers are starting to manage the exodus

When a service technician with more than 30 years of tenure at Ingersoll Rand Plc told his bosses he was considering retirement—his knees were no longer strong enough for him to climb rooftops—they created a new job for him and urged him to stay on. Now he works part time from home. Less experienced technicians send him photos of the equipment they need to repair and, using their headsets, confer about how to proceed.

“They’re getting trained, and our older technician, who knows our products so well, can keep working with us for many more years,” says Michelle Murphy, chief diversity officer and vice president for global talent acquisition at the industrial equipment maker. She wants employees in their 50s and 60s, who make up about a third of the company’s workforce, to collaborate with managers about their retirement plans.

“If they suddenly announce they’re retiring in 30 days, that doesn’t allow time for them to transfer all the knowledge they have, so we’re

inquiring: ‘What are your possible intentions? And, oh, by the way, instead of fully retiring, you can possibly work part time,’” she says. “We don’t lock people into a specific retirement date, we just want to work with them about their choices and our talent needs.”

With 10,000 baby boomers turning 65 every day—and continuing to do so for the next decade—employers are grappling with how to handle the exodus. They can’t assume all older workers will depart when they reach 60 or 65. Mandatory retirement no longer exists at most companies, and employees increasingly want or need to work through their 60s and beyond because of longer life expectancies and insufficient retirement savings. Yet managers must tread carefully when asking about retirement plans. Although they can inquire about employees’ interest in remaining with the company, for planning purposes, if they refer in any way to an employee’s age—with questions like “Aren’t you ready to ▶



◀ spend your time golfing?”—they can be accused of age discrimination.

Only about half of employers have a clear understanding of when their workers will retire, according to a recent survey led by Robert Clark, a professor at North Carolina State University’s Poole College of Management, and Willis Towers Watson, a risk management firm. About 80 percent of survey respondents said their company has a significant number of employees approaching retirement age and acknowledged that managing the timing of their departures is an important business issue. But only 25 percent said they’re doing this effectively; about 44 percent said they were having difficulty finding workers with the same knowledge and skills as retirees. “A lot of companies don’t recognize the expertise of older workers until they’re gone,” says Martha Deevy, associate director of the Stanford Center on Longevity. “Then they have to recruit and bring new people up to speed, which is costly. It makes more sense to see if older workers want to stay longer and to make sure they transfer their knowledge before they leave.”

The largest military shipbuilding company in the U.S. does both. More than a decade ago, Huntington Ingalls Industries Inc. realized it was on the brink of losing thousands of its most skilled workers as boomers started to retire. “We’ve always grown our own talent and knew we had to plan for a very large transition,” says Bill Ermatinger, executive vice president and chief human resources officer.

The company, which has about 40,000 employees, now has multigenerational work teams, a rotation

program enabling some workers to do different shipyard jobs for several months at a time, and reciprocal mentoring programs: Older workers pass on their shipbuilding expertise to younger colleagues while getting help from them on using new technology. They can work past traditional retirement age if they choose. The hourly workforce includes 31 silent generation employees who are in their mid-70s or older.

Every year, Huntington Ingalls identifies so-called legacy builders—employees who have knowledge it wants to document and preserve for up-and-comers. The company is recording videos of some of them as they perform tasks and talk about how they do their work.

Not all the legacy builders are older employees, and managers don’t mention the word retirement when seeking to record them. “I wouldn’t say, ‘I think you’re retiring soon,’ because maybe they aren’t,” Ermatinger says. “Instead, I’d likely say, ‘You’re the shipyard expert in this and this, and we’d love to know how you do it and share that with others.’ We’re targeting people with critical skills, not people of a certain age—so perhaps it’s a 65-year-old or maybe a 40-year-old.” Ermatinger thinks many companies don’t adopt such programs, because they worry about the short-term costs. “We always take the long view,” he says. “We want our employees with us for 40 years, not five.” —*Carol Hymowitz*

**THE BOTTOM LINE** Trying to manage boomer retirements presents challenges, since an employer can’t explicitly raise the issue of age. There are ways to talk about an employee’s intentions and options to keep working.

# It’s Never Too Late to Save

## Empty nesters can easily hike 401(k) contributions

Looked at your 401(k) statement lately? Your investment accounts are probably doing well overall, but the total may still seem too small to maintain your lifestyle in retirement. You know you should have saved more in your 20s and 30s, but it wasn’t easy with a layoff, two kids, buying a home, and taking vacations. Now you’re fifty-something, and the college bill for your youngest child

looms. The family car needs to be replaced soon, too.

You wish you’d followed the classic advice in the 401(k) literature to regularly set aside at least 10 percent and maybe as much as 20 percent of income in retirement savings. The longer you wait, the higher the odds you’ll end up scrimping later in life. The save-early-and-steady mantra is sound, yet the recommended percentages are often unrealistic. It’s little wonder the median combined 401(k)/individual retirement account balance for working households nearing retirement was only \$135,000 in 2016, according to the U.S. Federal Reserve. That sum would provide about \$600 a month in retirement as an annuity.

“People feel very pressured,” says Michael Kitces, director of research at Pinnacle Advisory Group, a wealth management firm. “They aren’t saving enough, and they look at their household expenses and wonder where the savings will come from.”

Despair shouldn’t be the default reaction. People approaching the traditional retirement years with a savings shortfall are far from doomed. Instead, they have an

Respondents who agree that “I expect to postpone my retirement due to my financial situation”

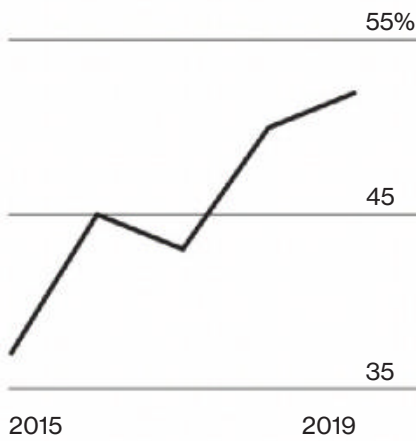

Expected sources of retirement income

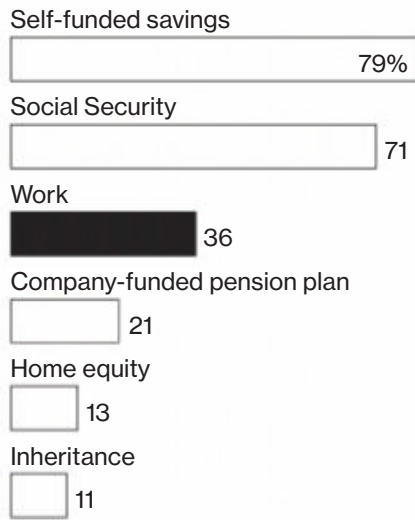

opportunity to shore up household finances by continuing to earn an income, especially if they’re empty nesters. “When we talk about people who are behind, the No. 1 solution is working longer,” says David Littell, a professor of retirement income at the American College of Financial Services. “It has a huge, positive impact.”

Empty nesters are well-positioned to save substantial sums now that they’re no longer raising children. Kids need food, clothing, education, and child care, as well as smartphones. Well-off married parents with a child born in 2015 can expect to spend \$372,210 on child-rearing expenses from birth through age 17 (in 2015 dollars), calculates the U.S. Department of Agriculture. Not surprisingly, household cash flow improves once the kids are out of the house and self-sufficient. “The lift comes from disposable dollars,” Kitces says. “It’s a material amount of money.”

That’s the experience of Kate Barr, 63. As president and chief executive officer of Propel Nonprofits in Minneapolis, she advises organizations in the Upper Midwest on strategy, finances, and corporate governance. Barr has had a varied career, including as a dancer after college and a long stint as a senior executive at a community bank. She and her husband had two children, who attended liberal arts colleges. They made sure the kids graduated without student loan debt. “We don’t have their costs,” Barr says. “We’re also not revolving our time around them. I’m continuing to work and max out my retirement savings contributions.”

Scholars at the Center for Retirement Research at Boston College offer this hypothetical: a married couple raising two kids and making \$100,000 combined, who contribute 6 percent of their salary annually to a 401(k) while the kids are still at home and in college. Once the kids aren’t a factor financially, the couple could put 18 percent of their earnings into the 401(k)—a 12 percentage point hike.

The opportunity to save for empty nesters has two big implications for retirement planning. First, the most important investments for experienced workers are in improving

their job-related skills. “Our safest asset is our human capital, our ability to work,” says Carolyn McClanahan, an M.D. and certified financial planner at Life Planning Partners Inc. in Jacksonville, Fla. Littell, of the American College of Financial Services, expects planners to devote more time advising clients to maintain a healthy lifestyle, nurture their network of industry contacts, and develop deep professional ties. “One of the things we’re starting to put into the curriculum is, ‘If working longer is so powerful, how do you make sure clients have employable skills?’” he says.

Empty nesters need to salt away much of their newfound cash flow. There’s nothing wrong with taking an extra vacation or spending more on a hobby. Even so, Kitces says they could probably hike their savings to 25 percent to 30 percent of income (including into retirement plans) once they’ve only themselves to support. But the evidence so far suggests households are raising their savings rates by just a fraction of that amount, less than 1 percentage point on average, according to a 2016 report from the Center for Retirement Research. Behavior may change as working longer becomes increasingly common. The civilian labor force



participation rate of Americans age 60 to 64 rose to 57 percent in 2018, from 44 percent in 1987, according to a report from the Brookings Institution. Participation increased to 33 percent from 20 percent for those 65 to 69 years old.

Knowing there’s time to save for retirement later in a career is liberating. And easier than many expect. Barr examined her spending and saw that the biggest payments went to entertainment, charity, and travel—quite a change from the six to seven years she and her husband were paying college tuition. Says Barr: “You do have time to restore your finances.” —Chris Farrell

**THE BOTTOM LINE** Savings behavior often changes for older workers as the money they spent on raising and educating their children is freed up for retirement plans.

# ● The Future Of Germany

# ○ The country's prosperity is on of a reversal. An seems ready for

By Alan Crawford

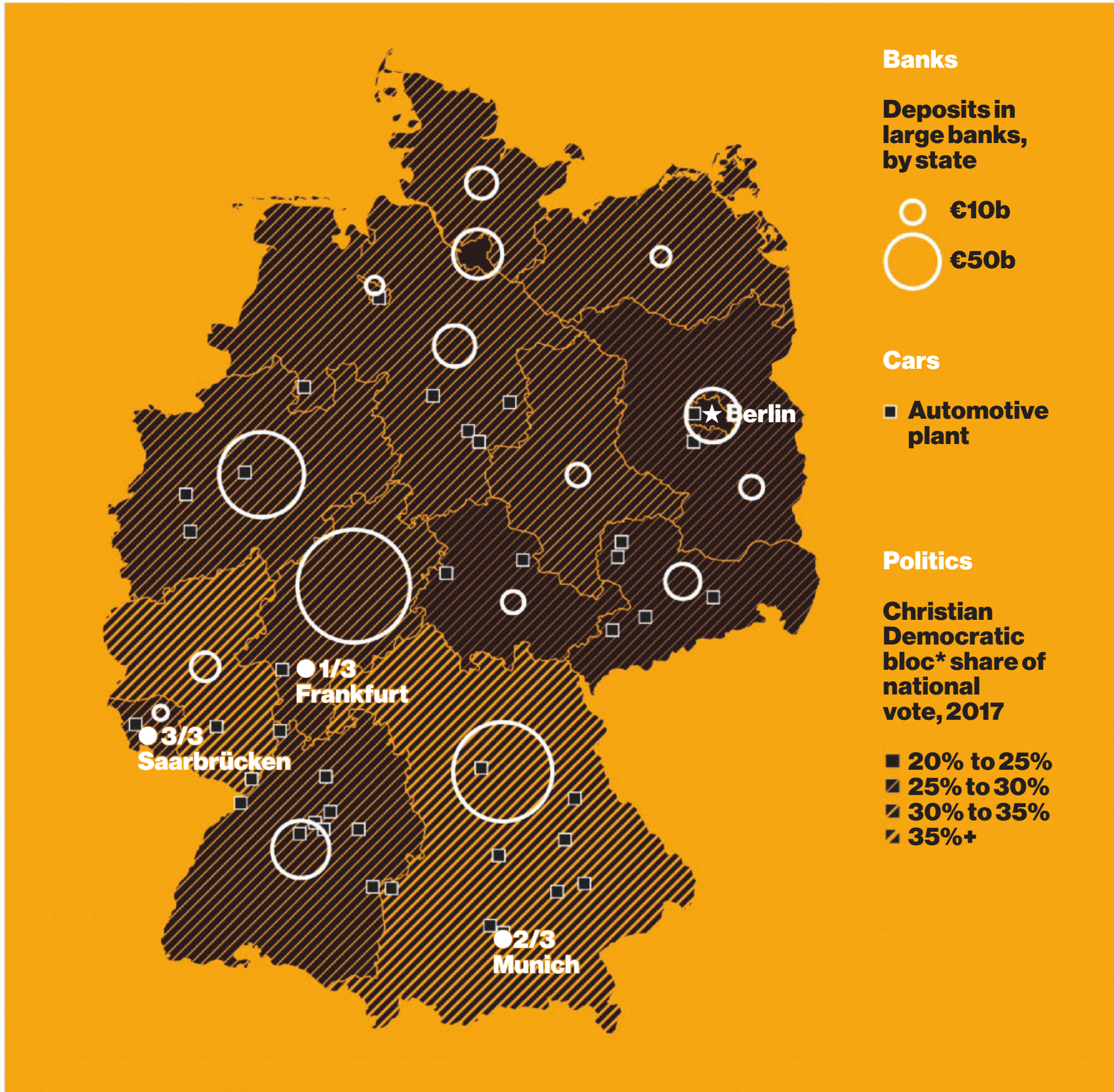

44

\*CHRISTIAN DEMOCRATIC UNION AND CHRISTIAN SOCIAL UNION; DATA: DEUTSCHE BUNDESBANK, COMPANY REPORTS, BADEN-WÜRTTEMBERG STATISTICAL OFFICE, GERMAN FEDERAL RETURNING OFFICER

# postwar the verge d no one it

## ● 1/3

**An awkward path to profitability for Deutsche Bank 46**

## ● 2/3

**BMW and the German car industry could be left in the dust 50**

## ● 3/3

**Is Merkel's likely successor up to the job? 52**

Anniversaries can be painful for Germany, and this year is full of pivotal ones. It's the centenary of the Treaty of Versailles, which imposed punitive reparations on the country at the end of World War I and laid the foundation for the next conflagration. It marks 75 years since the D-Day invasion, which led to the toppling of the Nazis 11 months later. And it's 30 years since the Berlin Wall fell. That symbol of the Cold War's demise is also a reminder of the post-reunification divisions—financial, social, and political—that persist between the country's east and west.

This year is shaping up to offer another uncomfortable milestone: the moment Europe's biggest economy is forced to come to terms with its shortcomings. Germany today feels like it's living out the final days of an era; there's an air of impending change for which no one seems prepared. The country remains wealthy and politically stable, but it's hard to escape a sense that Germans are complacent about the threats to the foundations of their prosperity.

The twilight of Angela Merkel's long chancellorship is at the center of this atmosphere. She's led the country through global crises—the 2008 collapse, the Greek meltdown, the influx of refugees, and various threats to the euro. Merkel was the champion of austerity, and yet her stewardship of the German economic engine kept the continent stable. Her handpicked successor, Annegret Kramp-Karrenbauer, is a mostly unknown quantity. Her main achievement so far is fending off an anti-Merkel candidate to head the Christian Democratic Union party.

Beyond politics, there's a technological revolution that will likely mean the end of the internal combustion engine. The German auto industry—from BMW to Mercedes and Porsche—directly employs 800,000 people and has an export value of more than €240 billion (\$269 billion), according to the German Association of the Automotive Industry. Volkswagen AG remains the world's biggest automaker by sales volume, its admissions of emissions cheating notwithstanding. But the country

that developed the first modern car in 1886—a Benz, more than two decades before Henry Ford's Model T—has been slow to shift to electric vehicles. That casts doubt on how much longer Germany can maintain its dominance of the global luxury-car market in the face of competition from China and elsewhere.

Then there's the sclerotic banking sector. The Finance Ministry's attempts to press once-mighty Deutsche Bank AG to merge with Commerzbank AG may save neither. Without a viable banking behemoth, where will German enterprise look for financing?

None of this bodes well for the country's outward-facing economy. The world's third-biggest exporter, Germany is more exposed than its competitors are to the headwinds of a global trade war. The outlook for growth this year has been slashed amid an alarming slump that's dragging down all of Europe. Meanwhile, fellow Group of 20 nations from Brazil to Italy are following Donald Trump in turning inward and adopting nationalist programs. Germany is isolated, exposed to overseas agendas that are echoed—faintly but worrisomely—in its own homegrown populism.

Yet it's not all gloomy. Berlin is booming, and the benchmark DAX stock market index is up about 13 percent so far this year, as investors shrug off signs of economic weakness. The legions of small and midsize companies that make up the mighty *Mittelstand* remain innovative and highly specialized in premium niche areas. Germany is the third-most-automated country in the world. The shift to clean energy has turned the nation into a global center of renewables technology.

There's another anniversary this year: Postwar Germany's constitution came into force 70 years ago in May, and four months later the first federal government was elected, with Konrad Adenauer at its head. The economic miracle—*Wirtschaftswunder*—was just around the corner. If Germany can recover that spirit, this year may yet mark one more turnaround. **B**



● 1/3

● Making a Big, Messy Bank Even Bigger

○ After years of trying to get out of its funk, Deutsche Bank considers a deal with Commerzbank



By Edward Robinson  
and Steven Arons



Since it was founded in 1870, Deutsche Bank was supposed to be a steward for German industry, helping the nation's manufacturers finance overseas trade. Broken up into 10 banks after World War II, it regrouped and prospered along with West Germany and, much later, a post-Berlin Wall, reunified nation. It's long strived to be more than just another lender. And since the 1990s, it's tried to go toe-to-toe with U.S.-based powerhouses such as Goldman Sachs Group Inc. in global investment banking, the business of trading and underwriting securities and providing financial advice to corporations. Germany—and Europe—had nothing to match the Americans on that scope.

Even as its European rivals were scaling back their businesses and ambitions to adjust to the postcrash world, Deutsche Bank AG pushed further into new markets and new businesses, with a vision to project German financial might onto a global stage. Now that ambition is in tatters. The lender has burned through chief executive officers and launched four turnaround plans in recent years. It's been trapped in a spiral of falling revenue and rising costs. Because of intense competition from Wall Street, it's struggled to boost sales at the investment bank. But it's also been reluctant to make deep cuts there, in part because the division also provides more than half of revenue. Europe's sluggish economy and low interest rates haven't given the bank much of a margin for error.

Today it's considering a takeover of its main national rival, Commerzbank AG, which has also been in a slump. German Finance Minister Olaf Scholz has egged the deal on. The idea is that fusing two weak banks will forge a stronger one that can better withstand the next recession or financial crisis. The German government still holds a 15 percent stake in Commerzbank, a legacy of bailing out the lender a decade ago. European bankers and investors are riveted by what might happen next. If this deal fails, some speculate that a lender from outside Germany, such as Italy's UniCredit SpA, will take a run at Commerzbank. Even Deutsche Bank could be vulnerable to a takeover from

outside Germany. That foreign incursion would be a blow to the country's pride.

Deutsche Bank's future is a question of national importance. More than almost any other large country, Germany's economic growth is dependent on its export industry—much of which relies on Deutsche Bank and Commerzbank to provide trade finance and other crucial banking services such as payments and risk management products. As concerns over the next recession are beginning to swirl in Europe, so are worries mounting that Germany may not have much of a domestic financial industry should it strike.

Scholz took an activist approach to the problem. In April 2018, a week after Christian Sewing became Deutsche Bank CEO, the finance minister drew him aside at a Prussian palace in Berlin during the German banking association's annual reception. While it's not known what was said, the 15-minute exchange marked the beginning of a thaw in relations between the government and the financial giant.

Even so, Sewing continued to resist a merger. He asked for investors' patience as he focused on cutting expenses and stabilizing market share and said it would take several months before he would consider a deal as a solution to the bank's woes. But he struggled to create a positive narrative. Over the past 12 months, Deutsche Bank's shares have declined more than 37 percent.

A slew of awful headlines hasn't helped. Earlier this year, it emerged that the U.S. Federal Reserve is reviewing Deutsche Bank's handling of billions of dollars in suspicious transactions from Danske Bank AS, a Danish lender swept up in a €200 billion (\$225 billion) money laundering case. Deutsche Bank said at the time it was providing information to law enforcement and regulators. In a separate matter, prosecutors in Frankfurt were looking into whether an obscure entity called Deutsche Bank Global Trust Solutions turned a blind eye when clients laundered dirty money and dodged taxes from 2013 to 2018. In November, 170 German law enforcement officers descended on Deutsche Bank's headquarters and carted away boxes ►

◀ of files and computers. The bank denied wrongdoing and said it was fully cooperating with the inquiry. But the raid eroded confidence in the institution as it seemed to lurch from one fiasco to the next. By March 17, Sewing announced that the lender was starting formal tieup talks with Commerzbank.

There's been a strong backlash to the potential deal. It would make a bank that's already too big to fail about a third bigger. And it could eliminate as many as 30,000 jobs, say people familiar with the potential transaction. German newspapers have lambasted the proposal as a "disgrace," and unions representing bank employees have vowed to boycott negotiations with bosses at both institutions if the idea isn't abandoned. Moreover, Deutsche Bank may need to sell billions of euros of new shares to cover the cost of a merger, a move that would dilute the stakes of existing shareholders.

Even so, Sewing and Chairman Paul Achleitner see little choice but to consider a linkup, say people familiar with their thinking. Deutsche Bank has lost money in three of the last four years. Last year revenue from trading was 40 percent less than in 2014. "Something has to give," says Oswald Grübel, the former CEO of Swiss banking giant UBS Group AG. But he adds, "They have huge problems to solve, and I think a merger would make the whole situation worse."

One reason to come to the table is Deutsche Bank's rising cost of funding. Banking profits are largely a matter of basic math—does your lending and other business earn more than it costs you to borrow? The weak profitability has made investors and credit rating companies more concerned about the bank's ability to service its debt. It's been forced to pay considerably more to borrow capital than its rivals have. Moody's Investors Service pegs some of the bank's bonds one notch above junk status and has a negative outlook on the lender. The bank says it's doing everything it can to keep and even improve its rating. If a downgrade happened, "every financial risk committee on Wall Street would call a meeting and say, 'Can we, or should we, continue to do business

with Deutsche Bank?'" says Barrington Pitt Miller, a money manager with Janus Henderson Group Plc, which holds shares of the lender.

By merging with Commerzbank, Deutsche Bank would increase its deposit base by more than 40 percent, which should help lower funding costs. It would also expand the proportion of income from more stable business lines. The deal could provide another benefit: It may help preserve the bulk of the company's investment banking franchise in London, New York, and Asia.

This latest episode in Deutsche Bank's long-running drama has been building since the term of Sewing's predecessor as CEO. John Cryan, a Briton and former chief financial officer at UBS, had tried to shake up the German lender for three years. He derided investment bankers for expecting lavish pay simply "for turning up to work" and slashed their bonuses. He pushed hard to overhaul the company's convoluted IT infrastructure, which ran more than 40 operating systems, and to install controls against misconduct. He also vowed to trim expenses and boost revenue.

Cryan's changes were designed to deliver what he called "sustainable profits." Yet year after year, shareholders were peeved by the company's inability to produce just that. They weren't happy about slow progress in cutting expenses, either. When Deutsche Bank recorded only €26.4 billion in revenue in 2017, its worst performance since the crash, the board decided not to keep Cryan around. It replaced him in April 2018 with Sewing, then head of the private and commercial bank. Sewing is the first executive to lead Deutsche Bank in almost two decades who wasn't from investment banking.

The board was, in effect, conceding that despite three turnaround plans since 2015, management was still failing to reverse the bank's slide. Several analysts and shareholders blamed the investment side—especially its U.S. operations. But when Sewing unveiled his own turnaround plan a few weeks after taking charge, investors saw it wasn't much different from Cryan's. Once again, management decided to apply only

limited cuts to the divisions. Investors punished Deutsche Bank's stock.

Chairman Achleitner has also come in for criticism. Glass Lewis & Co., an influential corporate governance advisory firm based in San Francisco, said it had "substantial concerns" about the progress under Achleitner. The appointment of Sewing, it said, was likely the chairman's "final chance" to get things right.

As the bank's struggles deepened, anxiety mounted in Berlin. Scholz, the new finance minister, and his deputy, Jörg Kukies, were becoming concerned that Deutsche Bank couldn't rebound on its own. A merger with Commerzbank looked like a solution. It could put the bigger bank on a sounder footing without investing new taxpayer funds.

Scholz, a former leader of the left-leaning Social Democratic Party, and Kukies arranged a series of discussions involving Achleitner, Sewing, and Commerzbank CEO Martin Zielke, according to people familiar with the talks. The ministers were careful not to speak publicly about a potential deal, but they also didn't shoot down news reports about the talks and the government's tacit support for the idea of creating a national banking champion.

Deutsche Bank's travails are the last thing Germany needs as it copes with a weakening economy and a surge in political populism. A decade after the global financial crisis and long since most of Deutsche Bank's counterparts in the U.S. and Europe have rebounded, a nation that shuns credit cards and budget deficits somehow has a bank problem on its hands. While Chancellor Angela Merkel has distanced herself from the negotiations, Deutsche Bank's inability to recover under its own power puts her in an awkward position. For years, Germany has demanded that the countries in the euro zone clean up their banking industries and make sure they don't need taxpayer-funded bailouts. But now, if there's a combination, Berlin may wind up owning about 5 percent of the country's largest bank, mainly as a result of Deutsche Bank's strategic missteps.

The takeover "would reinforce the too-big-to-fail problem that could

## ● Costs as a Share of Income at Selected Large European Banks

Circle size corresponds to revenue.  
Figures are annual as of 2018

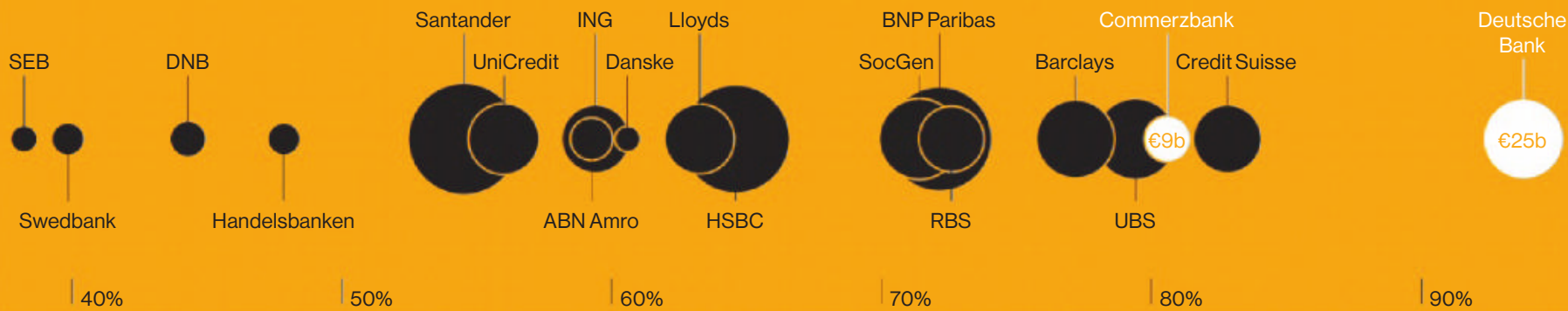

eventually fall back on the German taxpayer,” says Danyal Bayaz, a Green Party member of the Bundestag and member of the legislature’s finance committee. “If the banks haven’t managed to develop a viable business model 11 years after the financial crisis, there is no way that taxpayers should be put in a position where they could be asked to step in again.”

Deutsche Bank’s troubled trading arm will likely be considered by European banking regulators looking at the proposal, according to people familiar with the matter. They’ll want to know how much the bigger bank would still rely on the securities unit.

It’s unclear how the combined institution would be reorganized or who would make up its executive suite and supervisory board. The benefits of a deeper deposit base might be eclipsed by the overwhelming challenges of merging two complex organizations. In an era when digitalization is a top priority in banking, fusing the IT systems of Deutsche Bank and Commerzbank could be the last thing either one needs. Not unlike public railway projects, such undertakings are fraught with blown deadlines and cost overruns.

No company knows that better than Deutsche Bank: Nine years after it bought German consumer lender Postbank for about €6 billion, it’s now spending an additional €1 billion trying to consolidate the companies’ systems, and the job still isn’t done. A merger with Commerzbank “would tie the bank down for years to come and cause huge upfront costs, while any savings would come much later, if at all,” says Isabel Schnabel, a finance professor at

Bonn University and an adviser to the German government.

The problem is that Deutsche Bank may not have much of a choice. If the deal falls through, Sewing would be left with a fraying turnaround plan, and investors would likely demand that he rapidly come up with a new one. It’s just not clear what that could be other than even more cuts to a bank that’s unsuccessfully tried to shrink itself to profitability for the better part of a decade.

That’s why some, including Harry Harutunian, an analyst with Olivetree Financial Ltd. in London, see a tieup as the least bad option. Slashing costs too deeply in the investment bank will limit its ability to increase revenue, likely hurting profits and putting the bank at risk of a credit rating downgrade. It’s a vicious circle, to use the phrase of Deutsche Bank CFO James von Moltke. And there’s little hope the lender can pick up a “revenue tailwind” from Germany’s commercial banking market, which has long been a tough place to make money because of low interest rates and numerous state-backed competitors. That may be why, even now, the bank continues to add staff in markets such as the Middle East and South Africa in a hunt for business.

The path of cuts and more cuts might put Deutsche Bank in a position similar to that in 2009 of the Royal Bank of Scotland, a sprawling, intercontinental player then in need of wholesale restructuring. It took RBS a decade and £15 billion in reorganization costs to get back to the right size. “Deutsche Bank will have to take less risk in investment banking, and it will continue to lose relevance as

an international player,” says Klaus Fleischer, a finance professor at Munich University of Applied Sciences who’s studied the bank for years.

Whether Deutsche Bank merges or goes it alone, it will also need to end its habit of slipping into political or legal scandals. It wasn’t until 2017 that its management board started getting a detailed picture of how its many businesses signed up clients and monitored and controlled risk. That year, Deutsche Bank agreed with regulators in the U.S. and the U.K. to pay \$630 million to settle allegations that it helped wealthy clients transfer \$10 billion out of Russia from 2011 to 2015 in violation of money laundering laws.

More recently, Adam Schiff and Maxine Waters, the Democratic heads of two powerful committees in the U.S. House of Representatives, started hiring lawyers and readying subpoenas as they opened investigations to examine Deutsche Bank’s dealings with President Donald Trump. Before 2016, the bank made hundreds of millions of dollars in loans to the Trump Organization at a time when the group’s numerous bankruptcies had cut off funding from most other lenders. Deutsche Bank declined to comment on the inquiries, and the Trump Organization didn’t respond to requests for comment.

Maybe Europe does need its own investment bank as an alternative to U.S. powerhouses. The question now is whether the Frankfurt lender can ever be that institution—and what path the bank should ultimately take to help Germany prosper. **B** —*With Birgit Jennen, Harry Wilson, and Nicholas Comfort*

● **2/3**  
● **Engine**  
**Troubles**

○ **Trying Not to**  
**Be the Obsolete**  
**Driving Machine**

By **Elisabeth Behrmann and David Welch**  
Illustrations by **Chris Philpot**

Since the 1970s, BMW has branded its cars with the “Ultimate Driving Machine” tag line. But it might be more accurate to think of them as having the ultimate internal combustion engine. The one inside the upcoming M3 weighs 381 pounds; its roughly 150 moving parts catapult the car to 60 mph in under 4.2 seconds. As impressive as that is, the electric motor in

**BMW**  
**M3**



**381** pound engine  
**500** horsepower

**1,200** engine parts

● **Cost**

According to engineering firm Munro & Associates, it costs BMW

**\$3.5k-**  
**\$3.7k**

to build the M3 engine.

● **The technology**

An internal combustion engine consists of a fixed cylinder and a moving piston. When fuel is ignited, it combusts, and the gases push the piston—which in turn rotates the crankshaft. Ultimately, through a system of gears in the powertrain, this motion propels the car.

● **The plants**

- BMW has about 9,000 workers at its four engine factories in Germany, the U.K., China, and Austria (where, in Steyr, almost 6,000 engines are produced daily).
- The carmaker employs 4,100 people in Landshut, Bavaria, home to its light-metal foundry, where key engine parts are cast.
- The 3 Series is made in Munich; Dingolfing, in the state of Bavaria; and, until recently, Regensburg, also in Bavaria. In the future they'll roll off the production line in San Luis Potosí, Mexico.

● **Suppliers**

About **200** companies contribute parts for a BMW engine.

- Some pistons come from Federal-Mogul, based in Southfield, Mich., which was acquired last year by Tenneco Inc. from Carl Icahn for \$5.4 billion.
- Crankshafts arrive in basic form from Thyssenkrupp AG, in Essen in the state of North Rhine-Westphalia, to undergo further engineering in such places as Munich.
- Other German providers include Schaeffler AG in Herzogenaurach (transmission systems including clutches), Continental AG in Hanover (parts such as fuel injectors and engine control units), and Mahle in Stuttgart (cylinder liners, connecting rods), which together employ 414,000 people.

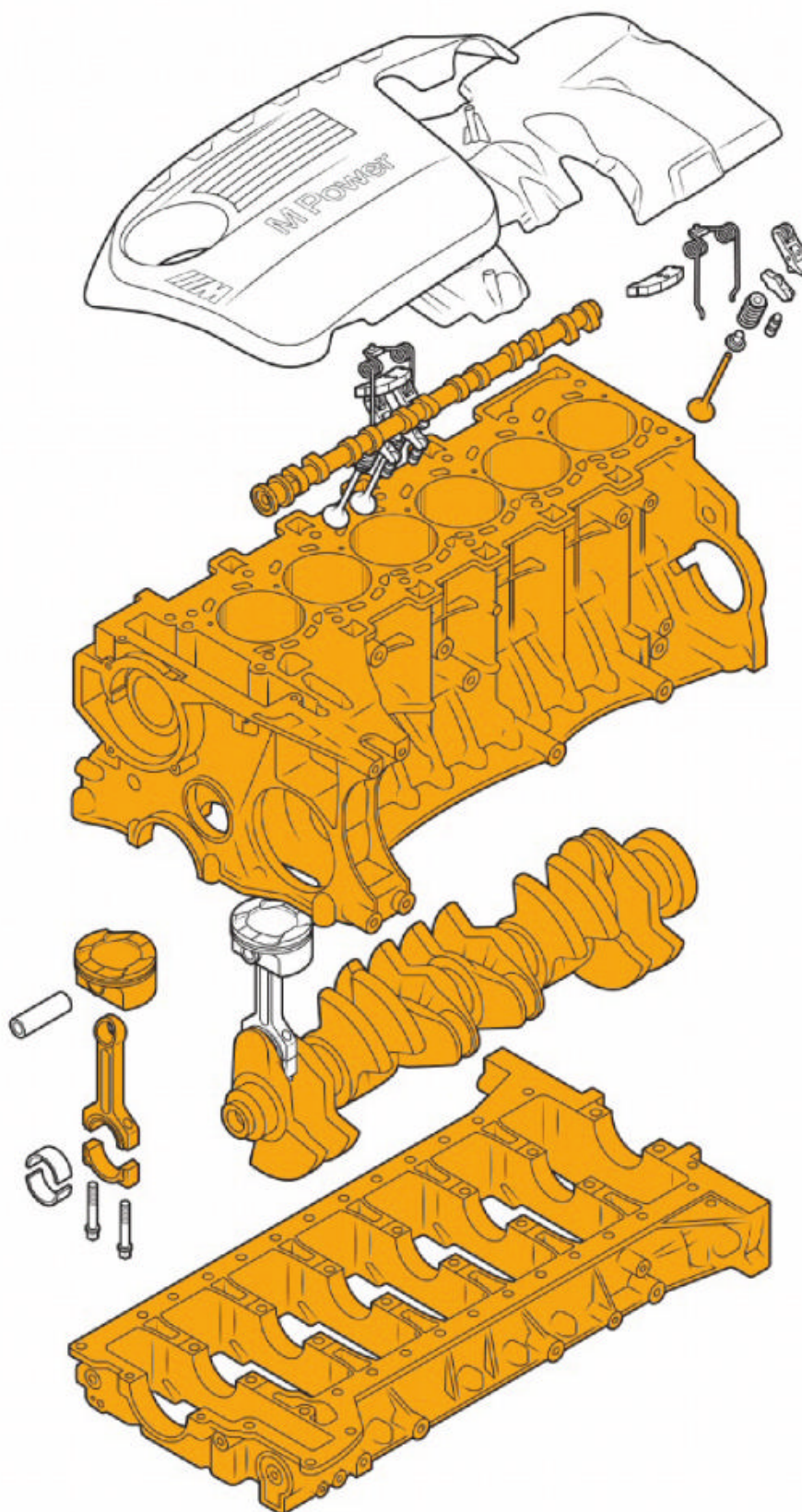

● **Production**

In 2018, BMW sold 2.5 million cars with combustion engines and 34,829 i3s, so battery car purchases were 1.4 percent of the total.

● **Casting**

The Landshut factory makes 5 million aluminum and magnesium casting components, such as cylinder heads, annually. The parts weigh a combined 86,000 tons, the weight of more than 11 Eiffel Towers.

● **Business plan**

- BMW is planning a **50%** reduction in powertrain options (variables such as front-, rear-, or all-wheel drive) to save costs starting in 2021.
- The Dingolfing plant, which makes plug-in hybrid versions of the 5 Series sedan, employed about 600 workers to make electric motors and battery packs in 2018. In the next few years, that number will rise to about **2k** and grow further as BMW prepares to sell a dozen battery-powered models by 2025.

BMW's i3—which, with two dozen total parts, is liftable by hand—can outgun the M3 from a standstill at a traffic light.

The switch to electric is a painful and expensive transition that will play out most acutely in Germany. In fact, BMW AG warned recently that it may have to pay more than \$1.1 billion stemming from a European Union probe into alleged collusion by German automakers

to delay the rollout of cleaner-emission cars. (BMW is contesting the allegations.) From 2007 to 2017, according to Accenture, carmaking accounted for 60 percent of revenue growth at the country's top 50 companies. The looming end of the combustion engine and a decline in car ownership will bring an overhaul of the world's fourth-largest economy. About a third of BMW's

133,000-strong workforce has been trained to handle electric vehicle production, but not all of those employees will be needed to make tomorrow's cars.

The reason is that EVs are simpler to build, needing fewer engineers to design them and fewer workers to assemble them. Just take a look under the hoods of BMW's M3 and its electric competitor, Tesla Inc.'s Model 3. **B**

# Tesla Model 3



**101** pound engine  
**258** horsepower

**50** engine parts

## ● Cost

According to Munro, the Model 3's motor costs

**\$754**  
to build.

## ● The plant

- Tesla employs 10,000 people in Fremont, Calif. Some employees put together electric motors, and some build cars and other major components. Tesla even assembles its own seats, which other carmakers typically buy.

## ● Suppliers

While Tesla engineers its battery pack and electric motor in-house, the company relies on conventional parts makers, too, according to Munro. Some of the major ones include:

- Brembo SpA in Curno, Italy, for brakes
- ZF, in Friedrichshafen in the state of Baden-Württemberg, for electric power steering
- Yazaki Corp. in Tokyo for cables and wiring harnesses.

## ● The batteries

Panasonic Corp. makes the cells in the Tesla's battery pack, which alone costs the company

**\$13k**  
per Model 3 to assemble (that's \$1,000 more than a Chevrolet Bolt pack), according to Munro, a figure that Tesla is working to reduce. A long-range Model 3 has a 75 kilowatt-hour battery pack with 4,416 cells that are each about 2.8 inches long.

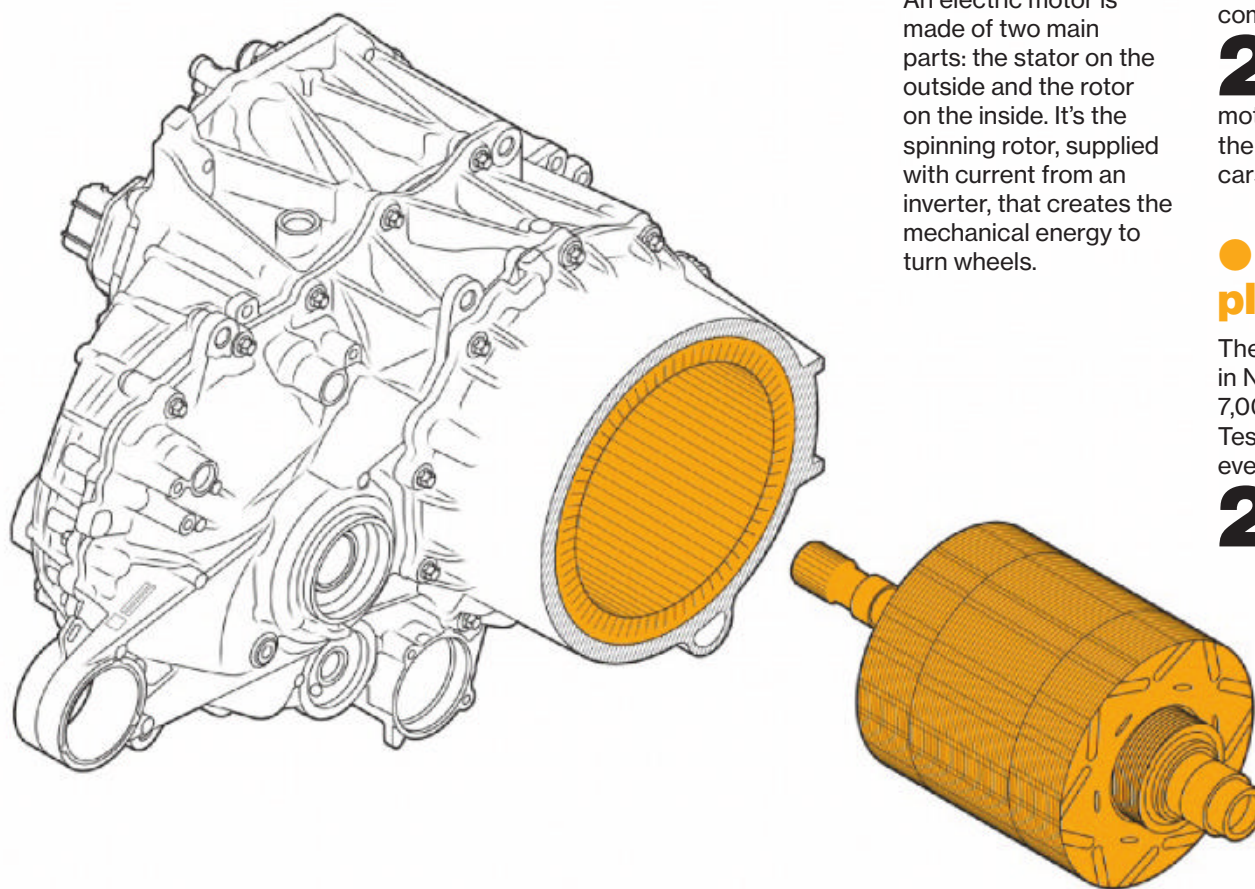

## ● The technology

An electric motor is made of two main parts: the stator on the outside and the rotor on the inside. It's the spinning rotor, supplied with current from an inverter, that creates the mechanical energy to turn wheels.

## ● Production

Since Tesla doesn't carry much inventory, the company made about **250k** motors last year for the same number of cars sold.

## ● Business plan

The new Gigafactory in Nevada has 7,000 employees, and Tesla has talked about eventually raising that to **20k**

Battery cell



Battery pack

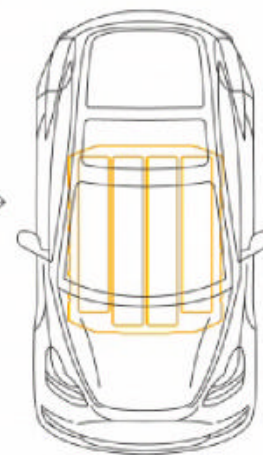
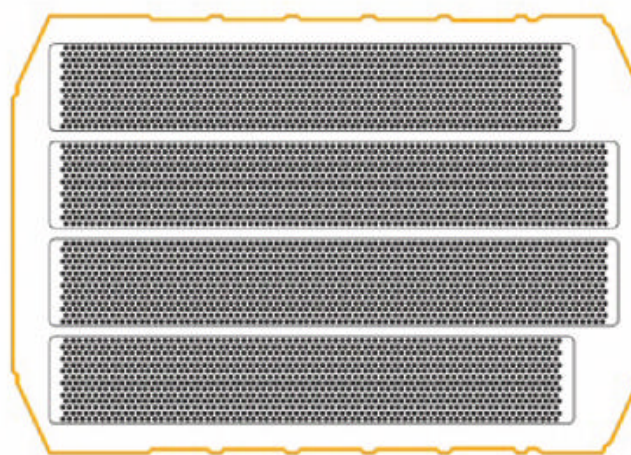

● 3/3

## ● Can This Woman Save Europe?

By Arne Delfs, Patrick Donahue, and David Rocks

The annual Ash Wednesday political roast in the Northern German town of Demmin is classic partisan shtick: Beer flows freely, the aroma of sausage fills the air, and assembled grandees make lame jokes about their rivals. Chancellor Angela Merkel had been a regular at the event for two decades, but this year she skipped it, ceding the headline spot to her handpicked successor as leader of the country's ruling Christian Democratic Union, Annegret Kramp-Karrenbauer.

A slight woman with a pixie haircut, Kramp-Karrenbauer—whose name is routinely shortened to AKK—was elected in December to succeed Merkel at the helm of Germany's center-right party. While Merkel remains chancellor, this puts AKK in line to take over for the long-time ruler in 2021, when Merkel's term ends, or sooner if she's forced out.

Since assuming the leadership, AKK, 56, has stormed across Germany's political landscape, seeking to establish her bona fides with conservatives put off by the CDU's leftward drift and to shed her image as a Merkel disciple. Her fiery speech in Demmin couldn't have been more different from Merkel's usual plodding rhetoric. Already under attack for an off-color joke she'd made at an event a few days earlier—about Berlin's culture of “third-sex bathrooms, for men who don't know whether they should stand or sit while peeing”—AKK

## ○ Annegret Kramp-Karrenbauer is likely to succeed Angela Merkel. She just has to convince voters she can stand on her own

raised the stakes by further ripping into political correctness. Requiring people to “weigh every word on a jeweler's scale” threatens to quash robust debate and destroy cherished traditions, she said. In response to news reports about a Hamburg school that had barred students from wearing American Indian costumes, she roared, “I want to live in a country that allows children to be children, to dress like Indians.” The crowd erupted in applause.

AKK and Merkel both rose to power in an alpha-male culture and share a sensible political style, but their differences run deep. Merkel, a former physicist who grew up in East Germany, navigated her early political career around the collapse of the Berlin Wall and served as head of multiple ministries for Helmut Kohl, the CDU chancellor who led the country through reunification. She became the party boss in 2000 and five years later led the CDU to a general election victory.

Before taking the reins of the CDU, AKK had little political experience beyond her tiny home state of Saarland, a 1,000-square-mile patch of wooded hills, shuttered coal mines, and struggling steel mills near the French border. But she's also much better at the flesh-pressing and baby-kissing parts of the job than Merkel is. While Saarland leans

left, AKK managed to win two elections there against the Social Democratic Party (SPD), which had governed the state through the 1990s and appeared poised to return to power.

Her victories are all the more remarkable given her vocal opposition to policies such as gay marriage (legal in Germany since 2017) and her support of obligatory national service. “She weighs her decisions carefully and brings others along with her,” says Monika Bachmann, the CDU's social services minister in Saarland, who served in AKK's government there. “She loves to talk to people on the street, and she listens.”

Following in Merkel's footsteps, though, involves more than just delivering electoral victories. Merkel has served as the symbolic keystone of European liberal democracy for the past decade, helping the European Union navigate the global financial crisis, the near collapse of the euro, and waves of Middle Eastern and African refugees. Since then she's lost support from the CDU's right wing and been forced to form a coalition government with the SPD. Meanwhile, the even-further-right Alternative for Germany (AfD) party has been picking off the most conservative voters. France's Emmanuel Macron has tried to step into the breach with pan-national plans for reform, but he faces his own electoral challenges at home.

AKK has distanced herself from the French president, warning of the danger of a European “superstate.” She's also taken aim at the White House, telling Bloomberg Television at the World Economic Forum in Davos that President Trump's adversarial political style “makes it more difficult to work together.”

Her critics argue that she lacks the policy chops to deal with an economic downturn, which some indicators suggest may be on the horizon. “AKK is a professional with great instincts,” says Oliver Luksic, a Saarland legislator in the Bundestag for the Free Democratic Party. “But she's not very competent when it comes to Europe and the economy. If she were confronted with another euro crisis, she'd find herself in unfamiliar territory.”

AKK was born into a conservative Catholic family in Püttlingen, a shabby former mining town of 20,000 about 25 minutes by car from Saarbrücken, the charming but not very cosmopolitan capital of Saarland. Although AKK professed a passion for the Scottish boy band the Bay City Rollers as a teen, she was more energized by conservative politics and joined the CDU in high school.

At 22, AKK won a post on the city council of Püttlingen. She became the local CDU chairwoman and a state leader of the party's youth wing a year later and quickly earned a reputation as a bridge builder with a "rational and pragmatic political style," says Rudolf Müller, who as Püttlingen's mayor encouraged her to run for office. When a local factory closed in the 1980s, he recalls, AKK worked with members of the local Communist party to create a training center that helped the 150 laid-off workers find jobs. In 1999, after several months of filling in for a retired member of the Bundestag, she won a spot in the state parliament and later ran a handful of ministries.

When she rose to become Saarland's premier in 2011, AKK confronted a state in turmoil. There was surging unemployment, a steel industry in sharp decline because of competition with China, and a budgetary shortfall as big industrial companies saw their profit—and their tax bills—plummet. She cut salaries for civil servants and reined in other public spending. Then, as thousands of mining jobs evaporated, she insisted on including labor representatives in talks with employers, helping to ensure that many former coal miners retired comfortably or found jobs in renewable energy. During the 2015 refugee crisis, she got credit for Saarland's well-ordered shelter system. She simultaneously backed the rapid repatriation of asylum-seekers whose bids were rejected—a nod to the party's right wing and a far tougher position than Merkel held at the time.

AKK's fans point to her time in Saarland as proof of her tenacity. Peter Jacoby, the state's former finance minister who's known AKK for more than 30 years, cites the way she persuaded wealthier German regions to divert

€500 million (\$565 million) in extra money to the struggling state in 2017. "AKK has already gone through the fire of political crises," he says

She also learned how to outmaneuver rivals. Eight years ago she was accused of grossly underestimating the cost of a museum expansion in Saarbrücken, and the Social Democrats convened two parliamentary committees to investigate her role in pushing the plans despite exploding costs. At the time, AKK headed a government of Greens and economic liberals, but when the inquiry started, she scuttled that coalition and formed an alliance with the Social Democrats instead. The probes were wrapped up quietly, and no charges were ever filed.



Kramp-Karrenbauer

If things had gone as planned, AKK would've had several years to prepare for the global stage, but setbacks in regional elections last fall and festering tension over Merkel's formerly open-door policy for refugees forced the chancellor to surrender the party leadership. Although it's possible Merkel will serve out her term, the Social Democrats' commitment to the coalition is fragile. If they were to pull the plug, AKK would be the leading candidate for the chancellery.

The concerns AKK dealt with in Saarland—ensuring that the high-speed train from Frankfurt to Paris passed through the state capital, managing the decline of the local coal industry—bear little resemblance to issues she'd face as

chancellor. Growth this year is forecast to be the weakest since 2013. Industrial output fell 3.3 percent in January from a year earlier, and the country narrowly avoided a recession at the end of 2018. Highways and bridges are crumbling, the population will start shrinking in the coming decade, and the crucial auto industry risks being sidelined by self-driving electric cars. Finance Minister Olaf Scholz recently said, "The fat years are over."

Even as she's been making many of the party's day-to-day decisions, AKK has been in an unofficial but intensive chancellor-training program. She's become a staple of the 24-hour news channels and is frequently seen on weekend political chat shows holding forth on the economy, refugees, and relations with the EU. In December she discussed Brexit with Prime Minister Theresa May at the British Embassy in Berlin. In January she made the rounds at Davos and met Irish Prime Minister Leo Varadkar to preview European parliamentary elections. She was off to Brussels in March to help formulate a response to the virulent nationalism of Hungary's Viktor Orbán. She's taking English lessons, the better to defend liberal democracy on the global stage.

For as much as she's tried to differentiate herself, AKK isn't abandoning the Merkel model entirely. As she hit her stride at the Demmin Tennis Center, AKK set aside the beer jokes and the culture war dog whistles to address a topic more typical of the chancellor's speeches: the breakdown of the post-World War II global order. Aiming far beyond the coal mines and ribbon cuttings of Saarland, AKK weighed in on European parliamentary elections, EU defense policy, and President Trump's decision to withdraw from a 1987 nuclear weapons treaty with Russia. That decision means Europe is "once again the plaything" of Cold War behemoths, she said. "We don't want that—and that's why we need Europeans to step up." The crowd responded with no less vigor than it had to her pronouncements on political correctness, a positive sign for those who'd like to see the European experiment continue. Her handlers might also have been relieved: Their training, it seems, is working. **B**



Thousands of  
Dominicans are  
hunting for a  
treasure that may  
not exist

54

# THE LEGEND OF JACINTO'S GOLD

By Joe Nocera

Photographs by  
Christopher Gregory



*Nelson Peña visiting ancestral Guzmán lands near Dicayagua Arriba in the Dominican Republic*



— 1 —  
The three short videos are shaky, a jumble of blurred images and muffled sound, giving the distinct impression they were shot surreptitiously. They show three people, two men in leather jackets and a woman wearing an elegant red coat, in the lobby of Credit Suisse Group AG's Zurich headquarters. The person taking the videos is also a man, also in a leather jacket; his arm flashes on screen here and there. The men are from the Dominican Republic; the woman, a Swiss citizen of Dominican descent, is their translator. It's fall 2017.

Two of the videos show the men riffling through documents before handing them to a Credit Suisse clerk. These documents are meant to offer proof that thousands of people from a



Still from a video shot at Credit Suisse in Zurich

Dominican family, the Rosarios, are the heirs to a multibillion-dollar fortune they believe resides mainly in Credit Suisse's vaults and those of Banco Santander SA in Spain. The Rosarios are being led in this quest by their lawyer, Johnny Portorreal Reyes. Portorreal is the one shooting the videos.

In the third clip, the quartet is ushered into a separate area off the lobby. They walk toward an antique trunk that's on display. Portorreal's two Dominican side-kicks pose on either side of the artifact. "This trunk is from Jacinto Rosario's era," Portorreal narrates in Spanish.

Jacinto and his father, Celedonio, are the ancestors said to have gathered the treasure their descendants seek. Family lore holds that they owned a gold mine in the Dominican Republic and regularly sent gold to Spain in the early to mid-1800s. They turned some of it over to the monarch and put the rest in a bank. Much of it was said to have been

moved to Switzerland about the time of the Spanish Civil War.

After pausing at the trunk, the group moves down a narrow hallway and enters a modest vestibule. "These are the offices they gave us," Portorreal says as his camera sweeps the space. "This will be for the Rosarios' activities at the bank"—activities, he's told them, that will make them among the wealthiest people in the world. "A beautiful place," he says.

— 2 —  
Six years ago, I received a phone call from a 45-year-old New Jersey man named Nelson Peña. He'd tracked me down after becoming obsessed with a documentary about bankrupt athletes in which I'd appeared as a talking head. Peña explained that he was Dominican and his family had known for generations that a great inheritance awaited them in Switzerland, but that they'd been unable to wrest it from the Swiss banking system. Believing it might finally be within reach, he thought I might be able to help him find a lawyer.

Peña isn't a Rosario. Rather, he's part of a smaller Dominican family, the Guzmáns. His story was similar, however: An ancestor he called his great-grandfather, José Eugenio Guzmán González, was a merchant and ship-owner who, according to Guzmán family legend, took Dominican gold to Spain in the late 1700s and presumably did the same thing Jacinto del Rosario would do decades later: give some to the king and put the rest in the bank.

Of all the random calls I've gotten over the years as a reporter, I'm not sure why I decided to pursue this one. Peña worked as a customer-relations manager at a small company in Midtown Manhattan, making \$50,000 a year. His wife, Jessie, was a surgical technician. They had four children. They weren't poor, but they didn't own a home or drive a late-model car, either.

Peña had an appealing sweetness about him. I knew the odds were against his family's unlocking some fantastic sum of money in Switzerland—but wouldn't it be wonderful if they did! He had no doubt the inheritance was real. He'd heard

about it his entire life. When he was a child, Peña's mother and her siblings used to talk about it; he even recalled his mother being visited once at her apartment in Queens by European lawyers who suggested she might be an heir. Lacking the means to get to Switzerland, she never followed up.

Peña had an older cousin, José Bienvenido Guzmán, known as Chito, who was so obsessed with the inheritance that in the early 1990s he sold a restaurant he owned in Upper Manhattan, moved to the D.R., and traveled the country searching for records that would prove the family's claim. The obsession cost Chito his marriage and most of his money, but he'd documented his ancestry well enough that Peña felt the Guzmáns had a chance with the Swiss.

I put Peña in touch with Michael Hausfeld, a plaintiffs' attorney who, in the late 1990s, sued Swiss banks for using secrecy laws to shield the assets of Holocaust victims from their descendants. In 1999 the banks settled for \$1.3 billion. Soon afterward the Swiss began changing their laws to make it a little easier for anyone who wanted to claim a dormant account.

Lawyers with Hausfeld's firm worked on Peña's case for about a year. But in April 2014 they sent him some bad news. As he put it to me in an email:

Hausfeld is reporting that the Expert could not find any assets under our Great Grandfather's name, Mr. Jose Eugenio Guzmán González. We are told that the case is officially closed and that the Ombudsman will not accept any more claims for the Guzmán name. We did achieve a final answer, a NAY in a world full of mayhem; besides what else would have all this money brought to our family but more grief and more problems.

And that appeared to be that—except it wasn't. In January 2018, Peña sent me an excited message saying the treasure hunt was back on. Chito, who'd since remarried a Rosario, had called him to say a lawyer was claiming to have found the Guzmán fortune.

The lawyer's name, Chito said, was Johnny Portorreal.

— 3 —  
The taxi driver was surprised when I showed him the address. It was in a rough-and-tumble Santo Domingo

neighborhood where tourists rarely ventured. The narrow streets were littered with garbage. The sidewalks in front of open-air bodegas were crowded with tattooed young men. And the handful of larger buildings were caked with dust, seemingly abandoned.

There was one exception. The three-story structure where the taxi dropped me off was vibrating with activity. Across the front read a sign: “Central del Derecho”—Legal Center. A crowd stood before some steps leading to the second floor. An additional two dozen people loitered nearby. When I reached the second floor, I saw others filling out documents, which they handed to clerks sitting behind partitions.

After a few minutes, someone pointed me toward a black spiral staircase. I made my way up and was startled to meet a bodyguard cradling a semiautomatic rifle. He smiled and pointed to a door. I walked past a tiny kitchen where a handful of women were cooking *sancocho*, a Dominican stew, and entered a large office that was only slightly more kempt than the rest of the building. About 20 people sat in chairs and on sofas, all facing a man who was perched behind a large desk, talking on his cellphone. He waved me to an empty chair.

This was Portorreal. He stood apart: He was tailored, for one thing, wearing a blue blazer, fitted jeans, and dress loafers. He looked younger than his 65 years, his face largely unlined and his hair closely cropped. His smile was enigmatic. Most of all, he had presence—the others in the room all took their cues from him, laughing at his jokes, listening raptly when he spoke, rising to anger when he was piqued. They called him “the doctor” in deference to his law degree, though few Dominican lawyers use the title.

It was late March. Peña was also in the office, having arrived on the same flight from New York as I had; it was his first trip to the D.R. since the Hausfeld search. He’d left his customer-service job and now had two delivery gigs, making maybe half his old salary. He’d also had a fifth child. By abandoning his

work and leaving Jessie to care for the kids and support the family, he was putting his employment and his marriage in jeopardy. But he talked about it as if he had no choice. Like Chito before him, he felt compelled to help the Guzmáns recover their long-sought wealth. His

coming across the Guzmáns’ money. The impression he gave was that the process of retrieving the Rosarios’ money was well under way while the Guzmán effort was just beginning. It was also clear the Rosarios believed their money was coming soon.



Chito Guzmán and Peña in Dicayagua Arriba

siblings, who’d lost faith years before, were furious with him for abandoning his family for this quixotic venture; Peña was hurt and angry that they weren’t supporting him even though he was trying to make them rich.

The majority of the people in the office were Rosarios. As Portorreal would later tell me, he’d been the family’s lawyer since 2011. He said he’d found their inheritances long before

When Portorreal finally got off the phone, I asked him how he’d found the inheritances. He responded with a disquisition, very little of it related to the money, that lasted at least an hour. As I’d learn over time, Portorreal was incapable of answering a straightforward question straightforwardly.

With Peña serving as interpreter, Portorreal told me about Spanish colonization of Hispaniola (the island now ►



*Portorreal at his office in Santo Domingo*

## Whenever I pressed Portorreal on a sensitive question, he would start in on another of his rococo stories

◀ shared by Haiti and the Dominican Republic) in the 1600s. Then he explained how, in 1649, two upper-class Spaniards, José Margarito del Rosario and Victoria Guzmán, married and moved to Hispaniola. The Rosario and Guzmán fortunes were thus entwined.

On and on he went. Eventually, he got to the Rosarios' story. For centuries, he said, they'd been landowners in and around the town of Cotuí, 65 miles north of Santo Domingo. Although they were successful farmers and ranchers, the area's true source of wealth was a gold mine Jacinto del Rosario was said to have owned in the 19th century. Everything changed in 1930, however, when Rafael Trujillo—the infamous “El Jefe”—took power and inaugurated a reign of terror that lasted three decades.

Every Rosario I spoke to afterward had horrifying tales of the family suffering under Trujillo. Armed men forced them off their land. Resisters were killed. Some Rosarios went into hiding. Papers documenting landownership were destroyed. The family no longer dared to discuss the inheritance openly. By the time Trujillo was assassinated in 1961, the Rosarios living in and around Cotuí were some of the poorest people in the country. Others had fled to the U.S. or Spain.

In the 1980s and '90s, the government took over the mine but ran it so poorly it was forced to close. In 2006 it was taken over by Canada's Barrick Gold Corp. and a minority partner, Goldcorp Inc. They committed \$3.7 billion to modernizing and expanding the mine, the largest foreign investment in Dominican history, and one that brought the companies an expanse of land to which the Rosarios laid claim. The country negotiated to get a 50 percent share of the mine's cash flow, and in 2017 the combination of taxes and royalties put almost \$181 million into the government's coffers.

Even before Barrick appeared, some Rosarios had begun questioning why they'd never been given the opportunity to reclaim their property. Once the company began operating the mine, the Rosarios still living nearby had a second complaint: Barrick was despoiling the area and making

the local population sick. (Barrick emphatically denies these claims.)

From time to time, lawyers would agree to represent the family, but nothing came of it. When Portorreal took on the case, he told the Rosarios he'd get billions of dollars in reparations from Barrick, both for the land and for the illnesses—skin lesions, most commonly—the company had allegedly caused. In return he wanted a 30 percent cut of whatever he won. Some family members felt his fee was exorbitant, but they were outvoted. In February 2012 he filed the first of a half-dozen lawsuits against the company.

Portorreal took the Rosarios' crusade to the streets, organizing protests, holding sit-ins, even making a four-day march to the Capitol in Santo Domingo. He would tell his clients he was in negotiations with Barrick, or that they were doing well in court, or that a settlement was near (all of which a Barrick spokesman denies was taking place). Portorreal told me in our first conversation that “a payment from Barrick Gold is almost here.” Yet after seven years, not a penny had changed hands.

Portorreal had long known about the Rosarios' inheritance, he told me. Everyone in the family could recall learning about it as a child. There were Rosarios whose relatives had gone mad dreaming about it. “We may not look it, but we're rich,” mothers would say to their children. He decided to pursue the inheritance, too.

He'd already overseen a massive three-year effort to collect genealogical documents going back four and five generations, to prove the Rosarios had valid claims to the land near the mine. Thousands of family members had searched church archives, municipal offices, libraries—anyplace that might have archived death certificates, marriage certificates, and the like. These same documents could be used for an inheritance search.

According to Portorreal's account, he then traveled widely in search of the money, to Spain and Switzerland, across Europe, and elsewhere. To pay for this, he'd rounded up a small group of

investors, promising them a sliver of the 30 percent he stood to gain if he landed the inheritance. In the Grand Cayman Islands, Portorreal said, he'd found his first Rosario account, containing more than \$700 million, as well as a helpful banker who told him what to look for at other financial institutions.

By the time he was done, in his telling, he'd found 12 accounts, primarily at Banco Santander in Spain and Credit Suisse in Switzerland. Most were in the name of Celedonio del Rosario, Jacinto's father. (He later told me he'd found more than 12 accounts.) As for the Guzmán accounts, he said he'd stumbled across them while searching for the Rosarios' money because, thanks to intermarriage, several of the accounts were in both names. He'd then found an additional half-dozen accounts under the Guzmán name alone. Over the years, he said, various family members had tried to get the accounts, but they'd been rebuffed because they didn't have the proper documents. A court had blocked the accounts, he said, which was why it was such an ordeal to get the money.

When I finally had a chance to get in another question, I asked Portorreal an obvious one: “How much money is there in total?”

He smiled, threw his hands in the air, and gave a helpless shrug, as if to say, *It's more than we can count.*

---

I'd made that first trip to the Dominican Republic thinking it wasn't completely impossible the inheritances were real. But I also knew it could be a con. Before leaving, I'd reached out to a Dominican lawyer who was a member of the Guzmán family. “To our knowledge,” he said, “this is a fable.”

Portorreal didn't make it easy for a skeptical journalist to believe. On subsequent visits, he'd get up from his desk and embrace me like a long-lost friend. He'd let me listen in on conversations and have me pose for photographs with visitors. But he wouldn't give me proof the inheritance was real. How could I find the Cayman Islands banker who'd helped him? He promised to get me ▶

◀ a name and number but never did. Ditto his bank contacts at Santander and Credit Suisse. I knew there was a woman in Spain named Carmen and another in Switzerland named Celeste who were acting as intermediaries, but again Portorreal demurred when I asked for their last names and phone numbers.

I spoke with David Laufer, the co-founder of a Swiss firm that helps potential heirs find old bank deposits. “I used to hear stories like this all the time,” he said. “It is extremely unlikely that a bank would keep track of any belongings that went back further than 1925. It’s too old.”

When I asked Portorreal and his aides how Laufer’s assessment squared with their claim that the banks held untold riches, they insisted the accounts containing the inheritances weren’t technically dormant. Rather, they said, the money was held in a different type of account that no bank would ever liquidate—special deposit accounts, they called them. It sounded like nonsense. But I also bumped into a former private wealth manager for JPMorgan Chase & Co. in New York—a woman who had nothing to do with the Dominican families—who said these types of accounts existed.

Whenever I pressed Portorreal on a sensitive question involving the inheritances, he’d start in on another of his rococo stories. He repeatedly told one about how, in 1965, when he was just 12 years old, he’d fought against the Americans during their brief invasion of the country; he’d thought of himself as a rebel ever since. He also told me one of his ancestors had written his country’s national anthem. He often invoked God—God who’d granted the gift of this inheritance to the Rosarios.

And then there was Barrick Gold. Always Barrick Gold. He’d flush with anger as he railed against the company’s perfidy. Once, he prophesied that if Barrick didn’t settle with the Rosarios, a “catastrophe” would cause the mine to explode and people to die. At which point, he said, “We will take to the streets, and no foreign entity will ever invest in the Dominican Republic again.”

At such moments, Portorreal sounded not just grandiose, but messianic.

He also, of course, sounded evasive. But if it was a con, what was its purpose? Given his arrangement with the Rosarios, he wouldn’t get his money until they got theirs. Besides, what con man spends most of his working hours for years on end with the people he’s hoodwinking? He’d been to Cotuí many times to lead protests. He’d delivered medical supplies to family members. His identification with the Rosarios seemed profound.

Finally, after I’d spent weeks asking for proof, Portorreal’s media aide sent me the three surreptitious videos Portorreal had taken inside Credit Suisse’s Zurich headquarters. He told me to keep them secret, especially from the bank. I had them translated, and the third one, the one with the trunk, did seem to imply that Portorreal had some kind of relationship with Credit Suisse. Through the aide, I asked Portorreal if I could accompany him the next time he went to Europe to visit the bankers. On such a trip, I thought, the truth would be revealed. The response came a few days later: Yes.

---

5

---

I was hardly the only one starving for information. So were the Rosarios and Guzmáns. When Portorreal held occasional family meetings, he would do the same thing he did with me: filibuster. His refusal to share information with his clients gave him enormous psychological power over them. They were always in the dark, invested in a charismatic but elusive man who said he had the key to unlock their treasure. To turn against him was to abandon the quest.

Their faith was most acutely visible on the private messaging service WhatsApp, where at least eight chat groups were dedicated to the inheritance search. They were a rich stew of rumor and gossip, but even more they were a place for the families to express their hopes and anxieties. Sometimes the groups were filled with giddy anticipation; other times, discouragement. What never flagged, however, was the belief that the inheritance existed.

I was invited into the WhatsApp

groups in early April, a few weeks after returning from that first trip to the D.R. The mood at the time was practically euphoric. The rumor mill held that four or five Banco Santander accounts would soon be distributed, quite possibly the week of April 15. In preparation, the Rosarios began opening accounts at the state-owned Banco de Reservas de la República Dominicana, or Banreservas. The chat groups had photos of what appeared to be international transfer documents, and some Rosario family members said they’d been given PINs that were supposed to unlock their accounts when the moment came. As the week got closer, family members posted pictures of the cars and mansions they coveted. On his Facebook page, Peña, identifying with the Rosarios, called it “the most anticipated week in family history.”

Finally, April 15 arrived. For five agonizing days, there was nothing—no news, no movement, no money. But late in the morning on Friday, April 20, with his office full of the usual onlookers, Portorreal took a phone call. He spoke quietly for a few minutes, then hung up and smiled broadly. Once the room had quieted, he announced that a transfer had just been made and some of the inheritance now resided in the Dominican Republic. Everyone in the room thought they heard Portorreal say the money had been deposited in the central bank—the Dominican equivalent of the Federal Reserve—though it’s unclear whether he actually did. Regardless, that’s what immediately spread through WhatsApp.

Inside Portorreal’s office, people began dancing deliriously, shouting praise to God. Cups of rum and beer were passed around. Portorreal took a swig from a wine bottle he’d filled with honey—honey being the same color as Jacinto del Rosario’s gold. As people milling outside the office heard the news, they too began celebrating, singing songs and drinking beer from big bottles that suddenly appeared. After a few minutes, Portorreal told those in his office to quiet down and began speaking.

“Wars have been fought for gold,” he said. “I do not know of any other more important activity that a man has

done in his life than the search for or acquisition of gold.”

I watched all of this unfold on WhatsApp, tracking the steady stream of audio and video clips. In spite of myself, I got caught up in the moment. Wondering if there might be a distribution after all, I headed back to Santo Domingo.

There was no distribution. On Monday, April 23, family members were saying that so many Rosarios were trying to open accounts, Banreservas had turned some of them away. (A bank spokesman denies this.) On Tuesday, the WhatsApp chat room was abuzz with rumors that two policemen had shown up in Portorreal’s office and taken him to the central bank (an event he later told me never took place). On Wednesday he released a video in which he obliquely acknowledged that he didn’t know if the funds were in the country. “There is no money without me,” he added.

The story was by now attracting local media, and on Thursday, with reporters circling, Portorreal held a news conference in his office. Asked where the money was, he admitted he didn’t know. But he’d soon find out, he said; he and his team were going to Spain and Switzerland to deliver a final round of documents. “We are going to visit six or seven banks,” he said. “We will have meetings and gain information. But you can be sure that if we get information about payments, we will tell the Rosarios immediately.” The family members cheered.

On Friday, the central bank issued a press release denying that it had ever received deposits, explaining that this wasn’t the role of a central bank and blaming the “false message” on “unscrupulous and ill-intentioned people.” A few days later, Portorreal, his aides, and some key family members flew to Madrid.

Before joining them in Europe, I had lunch with Chito and his wife, Isabel. She told me something I hadn’t known before. A Rosario, she’d submitted genealogical documents to Portorreal for herself and 13 of her relatives. They’d collectively been charged 5,000 Dominican pesos, almost \$100, to give Portorreal the power of attorney, and had each paid an additional

500 pesos in fees for the contracts that gave him his 30 percent. The total for the 14 of them came to 12,000 Dominican pesos, or \$238, around the country’s average monthly minimum wage.

Suddenly, everything started to make sense.

Peña was among those who traveled to Europe with Portorreal. By the time of the trip, he’d been in the D.R. for a month and had been named a “U.S. coordinator” for the Guzmáns, meaning he was supposed to persuade family

three hours north of Madrid, with two of Portorreal’s investors, brother and sister entrepreneurs. On his Facebook page, Peña posted pictures of the group standing in snow on a Spanish mountaintop. In Switzerland he met Celeste Trummer, Portorreal’s intermediary with Credit Suisse. On Facebook he posted pictures of everyone taking a boat ride on Lake Zurich. Sometimes, in the evening over dinner, he’d hear Portorreal and the others discuss preparations for the distribution. “Portorreal said he wanted to raise \$500,000 to get a secure compound, bulletproof vests, and so on, because he



*A makeshift cafeteria outside Portorreal's office*

members to dig up genealogical documents and become Portorreal’s clients. Although coordinators were meant to be paid, he’d yet to see any money.

Peña was now out of work, and his relations with Jessie had become extremely tense. She was the family’s only breadwinner, and she didn’t make enough to pay the bills and keep up with the rent. Peña’s siblings were also irate, because he’d persuaded their mother to give him her credit card to finance the trip.

And yet, when I saw him in Europe, he couldn’t have seemed happier. The inheritance had become his life; it gave him a kind of purpose his delivery jobs never had. In Spain he stayed in Burgos, about

feels his office will be in danger while the process is going on,” Peña later told me.

As always, Portorreal seemed glad to see me, and as always he seemed to be keeping me from talking to anyone who might offer specifics about his enterprise. The investors in Spain, Trummer in Switzerland, others I’d heard about in Santo Domingo and expected to interview—I got to none of them. Nor did I meet any bankers, though for a different reason. Near as I could tell, Portorreal didn’t have a single bank meeting the entire trip. The only time I knew for sure he’d entered a bank was when he and Trummer dropped off documents at Credit Suisse—supposedly the last ones needed to certify the Rosarios as the ►



## “Since I was a child I’ve been waiting to be shot at. I’m still waiting”

◀ rightful heirs to Jacinto’s fortune. The bank told Trummer it would get back to her with an answer in a month.

The group returned home. In an audio clip Portorreal posted shortly afterward, he assured the family the money would soon be theirs. “The time has come,” he said.

---

In late May, a Dominican journalist became the first person to publicly label Portorreal’s venture a fraud. Her name was Anibelca Rosario, and she was, in addition to being a regular on a *Morning Joe*-style radio show called *El Sol de la Mañana*, a member of *that* Rosario family. Her uncle was a Portorreal client and a believer.

After visiting the Central del Derecho to interview Portorreal and doing some other research, she laid out the story one morning, sitting at an oval table with the other *Sol* personalities. Portorreal, she began, was a man “selling an idea of an inheritance.” The word she used to describe his actions was *estafa*—scam.

The grift she outlined was along the lines of what I’d come to suspect: Portorreal was telling family members they had to pay him to become clients. About 10 minutes into her report, the guy I considered the most hotheaded of Portorreal’s aides called in, claiming the Rosarios had six accounts at Banco Santander containing more than €6 billion (\$6.8 billion). He added that much of it was already in the D.R. “It will be a transcendent event for the country, which will transform the Dominican economy,” he said.

“You have more money than the owners of the bank?” Anibelca scoffed.

The report caused an uproar in the WhatsApp chats, with many Rosarios furious at Portorreal. But not because they now knew they’d been hoodwinked; most of them believed Anibelca was either misinformed or spreading “fake news.” Rather, her account seemed to remind them of all the times they’d been let down. They fumed about how little Portorreal told them and how tired they were of never knowing when the payoff might come. There were Rosarios

who’d quit their jobs in anticipation. Sick people counting on the money for operations. Elderly Rosarios who hoped to see some before they died.

A week after Anibelca’s story aired, someone posted an angry audio clip on WhatsApp, aimed at Portorreal. “We want an immediate response before Sunday—a clear answer and no games: amounts, day, and time,” the man said. “There is no cave, country, sea, or other place for you to hide. The family has been warning you of the consequences that this situation may bring. This following Monday we will begin protests.”



*Family members celebrating word that European banks had released money; the news later proved untrue*

When I arrived at Portorreal’s office on Monday, hoping to witness the confrontation, it was already over. He and his aides were inside, joking and laughing. Earlier that morning, an unusually large group had gathered in an empty lot next to the office, but Portorreal had defused them with one of his trademark stemwinders. He’d also let it be known that “a Swiss bank” had \$10.5 billion waiting for them. “The Rosarios cannot be afraid,” he said. “We are a people of God. We will go where we have to go with the blessing of God.”

Speaking to me, Portorreal seemed almost giddy. “Since I was a child,” he said, “I’ve been waiting to be shot at. I’m still waiting.” As the day progressed, though, he began reflecting on the uprising

and grew angry. “There are a group of Rosarios who say everything I do is bad,” he complained. “They said we did nothing on our trips—that I didn’t make demands on the banks. And now they’re saying I’m going to rob them. I call them fleas, vermin, ticks. They spend their whole day on their couch, not working, waiting for their money.

“God doesn’t want to pay people of that nature,” he concluded.

He reached for a copy of his standard contract. “I have the right to end this contract,” he said. “Anyone who speaks against this office will be ousted.” He added that he had in mind 20 people who’d be cut off from the inheritance.

By the end of the day, Portorreal’s office had posted their names on WhatsApp. Later, when he and his aides were out to dinner, he checked the chat groups and noted with satisfaction that even his harshest critics were apologizing profusely, pleading to stay on as his clients. “This is too easy,” Portorreal said. “When I was a revolutionary, I was used to burning cars and tires.” Then he added, “As of tomorrow, we have no enemies. All our enemies have disintegrated.”

---

Over the next few weeks, Portorreal moved to restore his clients’ faith in him. He set up a website and told family members it was the only place they should check for information. He and an aide posted occasional video and audio clips claiming that certain steps were still needed but that things were progressing.

Meanwhile, someone posted on WhatsApp that third surreptitious Credit Suisse video—the one showing the room supposedly set aside for Rosario-related activities. The video made its way to Miguel Surun Hernández, the president of the Dominican bar association. Hernández was aware of the claims about the inheritance, and the footage heightened his existing suspicions. He decided to have the bar association investigate.

With the video now public, I sent a copy to a Credit Suisse spokeswoman, asking her what the room was. She told me it was merely a waiting room. I also

learned that Trummer had recently received a letter from a low-level bank official saying it couldn't find evidence of any business relationship with Celedonio del Rosario, Jacinto's father. A source told me, too, that Portorreal and his team would sometimes stage photographs while abroad to make it appear as though they'd delivered documents when they hadn't. And Trummer, it turned out, wasn't a key intermediary but a multi-lingual skin-care consultant who served as Portorreal's translator in Zurich. When I reached her in Switzerland, she told me she'd never once seen him in a meeting with a banker.

It was looking more and more like a con.

A group of Rosarios finally, slowly started peeling away from Portorreal. For some, it was news of the bar association investigation. For others, it was the lack of information coming from his office. Yet even those who were fed up rarely stopped believing the inheritance existed. And most hung on with Portorreal, however reluctantly, since they could see no other path to the fortune.

Portorreal began posting a series of odd audio clips on WhatsApp. "Even if I'm crazy, I represent you," he said in one. "There is no other person. There is no other lawyer. You have to support me as I support you. They offered me money to leave you, but I will not abandon you."

Soon, a new payday emerged: The money would come sometime between June 18 and June 23. The chat groups cranked up again. But this time, the mood was wary. Sure enough, a few days later, Portorreal's aide posted an audio clip saying there were problems that would likely cause a small delay. The aide then went on the radio and announced that an important audit had yet to be completed, and the payday would now be between June 30 and July 8. The WhatsApp posts were filled with despair:

People are desperate and they came [to the D.R.] with nothing. I know people who asked for loans because they expected to receive an inheritance and they promised to repay it on June 19.

Several people have called me and I have cried with them. There is one man they do not let see the chats. The man is desperate and they fear for his life. I say that the one who gives his

word has to fulfill it. This is not a walk to the beach that is canceled. You cannot play with the illusions of people.

This is like a novel. A day of terror, two hours of joy, then terror returns.

On Monday, June 25, Portorreal's credibility took the biggest blow yet. Alicia Ortega, a highly regarded TV journalist, devoted her weekly show, *El Informe con Alicia Ortega*, to the inheritance. Ortega is famous enough that on the two occasions when she interviewed Portorreal, the people outside his office applauded her arrival.

Her report was devastating. She'd gotten a copy of the letter Credit Suisse sent to Trummer—the one that said the bank had never had a relationship with Celedonio del Rosario. When she showed it to Portorreal, he replied that it covered only one account; there were others the bank had acknowledged. When she asked to see those letters, he replied that he couldn't show them to her because of family privacy issues. In the face of her questioning, Portorreal came across as evasive and at times incoherent.

As her show was ending, Ortega asked Portorreal why the Rosarios had needed to wait so long to gain their inheritance.

"Didn't they doubt Jesus Christ?" he replied.

9

I met dozens of Rosarios while working on this article. The ones whose stories stuck with me, as it looked less and less possible the fortune was real, were the group I'd met around Cotuí. They were dirt-poor; the area had little economic activity aside from Barrick Gold's mine. They complained bitterly that the land no longer yielded what it once had, attributing this to Barrick's presence.

Why, I asked them, didn't they leave?

"We are tied to this land because of our ancestors," a woman named Margarita replied. She began reminiscing about what Cotuí was once like. "In your backyard, you might be sitting on a big rock that had gold in it. You could dig and find gold easily. Imagine when this was virgin land and Jacinto was walking around!" she said. "When I was young, we used to have a farm, and I would

sell eggs to different families. Now that farm is gone. It is part of Barrick Gold."

Small wonder so many of them had stuck with Portorreal, who'd made their fight with Barrick seem winnable, then tapped into their family lore to offer them the world's largest consolation prize. What was a little bad news, next to that?

Mind you, the bad news was really piling up. In the wake of Ortega's report, Banreservas took out a full-page ad denying it had ever received funds on behalf of the Rosarios or had contact with anyone representing the family. The bar association was starting proceedings to suspend Portorreal's law license. And a federal prosecutor, Yeni Berenice, tweeted that an investigation into the Rosarios' situation was under way. Her office didn't provide the media with much information, but someone there eventually revealed to me that investigators believed Portorreal counted some 29,300 Rosarios and Guzmáns as clients. It was difficult to say exactly how much money that might have made him, but the amount Isabel had spent for herself and her relatives suggested it was well into the hundreds of thousands of dollars.

Portorreal fought his detractors aggressively. He filed a defamation lawsuit against Anibelca Rosario (later dropped) and marshaled 50 or 60 of his supporters to rally outside the courthouse on his behalf. He claimed, falsely, to have been vindicated by the bar association. He complained that there was a conspiracy, led by Barrick Gold, to deprive the Rosarios of what was rightfully theirs. He continued to post audio clips urging his clients to be patient and let the process play out. His office even posted pictures that included me, as if to suggest that the presence of an American journalist validated his efforts. Rumors began flying that some critical last-minute documents coming in from Spain would allow the money to be released. The payday was, of course, coming soon.

10

In her 2016 book, *The Confidence Game*, Maria Konnikova tells the story of a legendary con man, Oscar Merrill Hartzell, who in the early ►



Members of the Rosario family around Cotuí, clockwise from top left: Teresa Rosario; Bonifacio Vázquez Hernández; Julio Rosario Amparo and Orquídea Altagracia Rosario; Pedro Vázquez; Ana Julia Rosa Fabián and Viviana Rosario; Ramona and Ramon Rosario

◀ 20th century convinced more than 70,000 people that he was in a legal battle with the British government to gain access to a fabulous fortune left behind by Sir Francis Drake. Anyone who helped stake him would get a piece of the fortune, he claimed. When Hartzell was finally arrested, his marks were so convinced of his innocence that they raised more than \$400,000 to cover his legal bills.

So it would be with the Rosarios and Guzmáns, it seemed. Peña was among those who remained a believer. Now back home, he continually shrugged off negative news, chalking it up to bad information or bad intentions. He and Jessie were so far behind on their rent they were being evicted. But he refused to look for a job, instead spending his time scrolling through WhatsApp and calling his contacts in the D.R. Jessie seethed with frustration at her husband's refusal to get on with his life.

Finally, I confronted Peña with the possibility he'd been conned. I reminded him of how Portorreal had spent the European trip sightseeing instead of meeting with bankers. I pointed out that Portorreal had yet to offer any proof the inheritance was real. I warned him his obsession could cost him his marriage.

He listened quietly, neither arguing nor disagreeing. When I was finished, he said, "I just have to see this through to the end."

---

11

Last summer, I spoke with a Dominican lawyer and former presidential candidate named Hipólito Polanco Pérez. Polanco, who's widely believed to be planning another presidential run in 2020, was in the meantime taking on several New York-based Rosarios as clients. They wanted both to sue Portorreal and to pursue a claim against Barrick Gold. A few months earlier, Polanco told me, he'd gone to Portorreal's office for a meeting. He first asked Portorreal to hand over his clients' documents. Portorreal said no. Instead, he invited Polanco to "join the process," as Polanco remembered him putting it.

When Polanco refused, Portorreal took a different tack. His clients weren't just a group of people hoping to inherit money, he said. They were also a political force. In 2016, he claimed, he'd met with President Danilo Medina, who was running for reelection that year, and promised to put them at Medina's service. Medina handily won reelection, and Portorreal claimed some of the credit. (A spokesman for the Medina administration says it has no knowledge of Portorreal or the Rosario inheritance.)

Portorreal now made a similar offer: He'd be willing to put his organization at Polanco's disposal during the 2020 election, he said. Of course, he wanted something in return.

I will give you these people, Polanco recalled him saying, and then you can support our legal team. Polanco declined.

---

12

I went to the Dominican Republic one last time, in early November. Portorreal was still claiming a payday was near. Peña had arrived several weeks earlier, even though it meant his wife had to stop working so she could take care of their children. He said he'd been told to come by Portorreal's office because he was going to be paid for his work as a coordinator.

Needless to say, Peña didn't see any money. And the payday, once again, was being pushed back. Portorreal began blaming the government, which was now supposedly involved and claiming 3 percent of the inheritance. Meanwhile, the bar association had suspended his law license for two years, and the investigation by the federal prosecutor's office was ongoing. Banreservas continued to insist that it held no money for the Rosarios.

When I confronted Portorreal with what I was hearing, he acted as if nothing was awry. He denied his license had been suspended and professed to know nothing about any federal investigation. Yes, he said, the government was now involved, but that was good; it would help prod the bank to release the inheritance. Oh, one other thing,

he added, breaking into a big smile: He was thinking of running for president.

By year's end, some family elders in the D.R. were ready to join the New York Rosarios in pushing Portorreal aside and bringing in new lawyers. Still others stayed loyal to him. But no matter where they came down on Portorreal, they remained convinced there were billions of dollars belonging to them somewhere. In January, some Rosarios held protests in Santo Domingo, at the Spanish Embassy and the National Palace, demanding their inheritance. Rumors were still flying: Portorreal was still in charge; he was being ousted in favor of other lawyers; the money was in the D.R.; the money was still in Spain. In late January, when the new Spanish prime minister, Pedro Sánchez, visited the D.R. and met with Medina, some Rosarios were convinced the men were negotiating the inheritance's release from Banco Santander.

Working with a journalist named Monica Cordero Sancho in New York, I gave Portorreal multiple chances to respond to lists of questions, facts, and allegations that I planned to cover in this article. After chasing him for weeks, I finally got him on the phone and managed to go over a handful of things before he said he had to go. He didn't answer his phone for a scheduled call later that day, nor when I tried repeatedly afterward to reach him.

I've kept in touch with Peña, and his belief has never wavered. The payday is always just around the corner.

---

13

"It is more difficult admitting you've been fooled than it is allowing yourself to be fooled," a particularly wise post in the WhatsApp groups read. "But when you walk without shoes, and someone is offering you three and four hundred million dollars, and you think your children will not have a hard life, and you are riding a donkey and you are suddenly changing it for an airplane, the brain creates an illusion and you believe it. But there is no money, brother." **B**

—With Monica Cordero Sancho

# Bloomberg BREAKAWAY

**The summit for CEOs by CEOs**

June 17–18, 2019 | New York City

Join us for a day of newsworthy interviews,  
peer workshops and keynote addresses.

## **Speaker spotlight:**

**Ms. Minshew and Gen. McChrystal are just two of the many  
leaders joining us in New York for this must-attend summit.**



**General Stanley A. McChrystal**  
Co-Founder, McChrystal Group, Former  
Commander U.S. and International Security  
Forces, Afghanistan, and former Commander  
of U.S. Joint Special Operations Command



**Kathryn Minshew**  
CEO & Founder  
The Muse

**Apply to attend:**  
[bloomberglive.com/breakaway](https://bloomberglive.com/breakaway)

In Sheep's Clothing,  
an all-day listening bar  
in Los Angeles

# LISTEN UP

# PURSUITS

67

70  
How essential are  
essential oils?

71  
Hop to these crunchy,  
trendy eats

72  
Fat chairs, comfy seats

74  
The fight over sex.com  
was as sleazy as  
you'd think

75  
A pollution tracker  
you carry around

**A NEW CLASS OF COCKTAIL DEN AIMS TO  
PLEASE YOUR EARS AS MUCH AS YOUR TASTE BUDS  
BY MATTHEW KRONBERG**

April 15, 2019

Edited by  
Chris Rovzar

Businessweek.com

**W**alk into Bar Shiru, a cocktail lounge that opened three months ago in uptown Oakland, Calif., and the first thing you notice is the back wall, where about 1,000 vinyl records are lined on shelves 15 feet high. Most of them are jazz: Giants such as Miles Davis face outward alongside current stars like Kamasi Washington. A few albums from hip-hop and R&B artists, ranging from A Tribe Called Quest to Prince to Aretha Franklin, round out the mix.

After ordering one of the bar's signature highballs and finding a seat in the middle of the room, your attention will likely turn to the pair of Line Magnetic 812 speakers at the foot of this display. Their brass hardware, coarse-weave fabric screens, and top-mounted horns come off as relics from the 1950s. Nearby, the vacuum tubes of two LM-805IA amplifiers glow on either side of the DJ booth. But they're not here as a piece of expensive design nostalgia: This old-school, high-tech equipment renders beats and blue notes in the bilevel room with a you-are-there clarity.

Music—specifically, music played on a superior sound system—is becoming the latest competitive advantage for high-end bars and cafes. Spiritland, which opened a 180-person “listening room”-style restaurant in London's Royal Festival Hall in December, worked with custom speaker maker Living Voice to create its setup. In Sheep's Clothing, a new all-day audiophile bar in Los Angeles's downtown arts district, uses a \$12,000 pair of Klipschorns to broadcast a vinyl collection put together for the joint by Zach Cowie, the music supervisor who gave Aziz Ansari's *Master of None* its tuneful landscape.

These places and others like them are providing a dedicated space for music lovers. Some of them are cafes by day that become bars at night, often serving food. DJs are present but aren't the focus; there's no dance floor, no nightclub vibe. Listeners at these spots will be introduced to new tunes instead of the same notes they always hear.

If they're used to hearing anything at all. As anyone who's shouted her way through dinner knows, restaurants are in a noise arms race. You howl to be heard, and the music's volume is raised to cover the din. Sound waves ricochet off hard surfaces, distorting and losing detail with every bounce before they reach your ears, eventually forming a sonic sludge with your companions' voices. It's the auditory equivalent of corked wine.

Public Records, which opened this month in Brooklyn's Gowanus neighborhood, is the latest to combat this modern-day malady with high fidelity. It has a cafe, a cavernous bar, and an intimate “sound room.” While many of these venues list equipment manifests on their websites—catnip to a certain set—Francis Harris, DJ, composer, and partner, wants to keep the attention on the programming, not the acoustics. “Talking about expensive gear feels exclusionary,” he says.

Nonetheless, Harris and his partners, Shane Davis and Erik VanderWal, take their sound seriously. They worked with Devon Turnbull of Ojas, a design studio that's collaborated with LVMH and Supreme, as well as Jason Ojeda's Global Audio Systems, an immersive lighting, sound, and visuals company that's produced events for Sony, Timberland, and Visa.

Together they created a custom system with speakers that



A booth lined with acoustic dampening tiles at Spiritland

# HOLY SHHHH

MUSICAL TEMPLES WORTH  
A PILGRIMAGE

## SPIRITLAND, LONDON

The all-day bar's Living Voice-designed system soundtracks bleary-eyed breakfasts and DJ-driven evenings.

**On the playlist:** Frank Sinatra, Childish Gambino, Fela Kuti

**Gear on tap:** A hand-wired rotary mixer from Can Electric

**Drink to order:** Gimlet with gin and clementine shrub

## STUDIO EKSOTIKA, BALI

The focal point of this tiny lounge is a six-seat bar made from recycled timber and foam.

**On the playlist:** Rafika Duri, Devendra Banhart, Eric Serra

**Gear on tap:** Vintage cerulean blue JBL 4345 studio monitors

**Drink to order:** Spiced Dancer, with arak, honey, citrus, and soda

## BAR SHIRU, OAKLAND

Oversize photos of Nina Simone and Miles Davis in this 2,300-square-foot lounge double as sound-absorbing panels; elsewhere, the bar is outfitted in mid-century modern seating.

**On the playlist:** John Coltrane, Kendrick Lamar, Parliament

**Gear on tap:** Line Magnetic 812 speakers, a modern riff on the legendary Lansing Iconic

**Drink to order:** Shiru highball, with Japanese whisky, soda, lemon

## IN SHEEP'S CLOTHING, LOS ANGELES

Its playlists are released every month on Spotify, but hearing the songs on vinyl through its sound system is essential.

**On the playlist:** Bill Frisell, Robbie Basho, Cody Chesnutt

**Gear on tap:** Klipsch Klipschorn speakers, the gold standard since 1946

**Drink to order:** Tabako, with Taketsuru pure malt whisky, Maurin Quina, tobacco bitters

## PUBLIC RECORDS, BROOKLYN

Edgy programming, inspired by the shuttered downtown club Tonic, encourages left-field DJs and avant-garde musicians.

**On the playlist:** Yasuaki Shimizu, the Overton Berry Trio

**Gear on tap:** BGW amplifiers, the power behind some of New York's best-loved venues

**Drink to order:** Gin and tonic with grapefruit peel, white pepper, coriander, and chamomile

feature vintage horns from Altec Lansing, the historic American electronics brand. Their sound room was also built with input from Arup, a company that's brought acoustical engineering expertise to opera houses in Copenhagen, London, and Oslo. It was tested with a wide range of tracks, from the Eagles to Michael Jackson to Diana Krall. The real moment of truth, Ojeda says, came when they played one of Harris's own songs, which gave him a "holy shit" moment of sonic revelation.

Shirin Raza and Daniel Gahr, the wife-and-husband duo behind Oakland's Bar Shiru, had their eureka moment about four years ago on a vacation in Japan. Walking through Tokyo's Ebisu district, they happened upon tiny Bar Martha, one of the country's many *kissaten*, a class of cafes geared toward audiophiles. They'd proliferated in the lean years after World War II, when high-quality stereo equipment and imported records were beyond the average person's reach. Today, it's not hard to find one dedicated to your favorite music, whether classical or techno. Some play CDs, others cassettes, but jazz on vinyl is the most common. What Raza saw there was a place where people could "focus on music while being able to socialize, hang out, and have some good whisky," she says. "I was, like, Why doesn't this exist here?"

Her husband spent the last seven and a half years as an executive at the Oakland-based music service Pandora, most recently as group creative director, and thus had some opinions. (Gahr

recently left to focus on Bar Shiru full time.) "Music has become a little bit of a disposable medium," he says. "If you're just a casual listener, you don't really have a lot of motivation to buy or listen to an entire album." Instead, songs are marketed to get included on featured playlists for on-demand services. "Music isn't just an endless stream that could go on infinitely if you let



Octopus and pork belly at Spiritland



Tabako cocktail at In Sheep's Clothing



Public Records in Brooklyn

it," he continues. "We're not scared of the silence that comes when you're changing the record."

But hushed silence is not the goal of this new breed of bar. Creating a listener-friendly environment, in which people can have sonic revelations while still being social, has been "really interesting, to say the least," says Eliot Kessel, general manager of In Sheep's Clothing. His bar has one daily, midafternoon block, the "Lion Hours," during which conversation is forbidden. (The name is a nod to Tokyo's Lion Cafe, which has been playing classical music for discerning listeners since 1926.)

Other than that, the rules of decorum aren't nearly so dogmatic. A sign by the bar's entrance (through an unmarked door in an adjoining pizzeria) simply asks customers to keep conversations below the music. "It's starting to police itself," Kessel says. "Customers come up to me now, and they're like, 'Hey, can I tell this table next to me to lower their voices?'" **B**



# Dreams In a Bottle

DoTerra sells more than  
\$1.5 billion in essential oils a year.

Now it just wants to  
figure out how they work

By *Nikki Ekstein*

“Snake oil.”

My husband, an orthopedic surgeon, scoffed as I rubbed a few drops of lavender extract onto my wrist from a \$30 vial. I, too, am a skeptic of alternative medicine, but ahead of a trip to Japan, I was prepared to try anything to combat my typically terrible jet lag. The essential oils from DoTerra International had shown up in my Instagram feed as plant-based solutions for almost any modern discomfort. What did I have to lose?

Two weeks later we landed in Tokyo, and for the first time in my life I slept soundly upon landing. The lavender was a success. Less so was my test of Balance, a frankincense-based DoTerra blend. I mistakenly used it for midday energy, but it’s actually supposed to promote relaxation. Luckily, it had no effect at all.

Since starting in 2008, DoTerra has become the most influential purveyor in a fast-growing essential oils industry valued at \$5.1 billion in 2017 and projected to reach \$25 billion by 2024, according to Verify Markets. That’s largely because of its use of multilevel marketing, a commission format that rewards nonsalaried “wellness advocates” for selling the company’s products—a side hustle often carried out over social media.

Last year the company exceeded \$1.5 billion in annual sales, a benchmark that its closest competitor, Young Living, has also hit. Now, DoTerra is looking to broaden its reach with a handful of wellness clinics across the country; the first Prime Meridian Health outpost opened in October in St. George, Utah, and 20 more will pop up across the U.S. by the end of 2019.

Not yet sold on essential oils? Here’s the 101: They’re distillates of volatile aromatic compounds, which give flowers,

fruits, and tree bark their distinctive scents. “Brands like DoTerra have gone a long way in bringing essential oils to a much broader audience,” says Dr. Yufang Lin, an internist with the Cleveland Clinic Wellness Institute who uses aromatherapy in her medical practice.

But do they work? Lin says they can. Limited studies show that lavender minimizes anxiety, and peppermint supports digestion, for instance. For many other botanicals, she says, “long-spanning traditional use tells us that at least these herbs are safe to use.” Not exactly a ringing endorsement.

There just isn’t a lot of research out there. And risks—including how tea tree oil can have a neurotoxic effect on children or how basil and sage can stimulate uterine contractions in pregnant women—resurface now and again. “It’s a full-time job to stay on top of it all,” says Aimee Raupp, head of Chinese medicine at the Well, New York’s holistic health club. Both she and Lin emphasize the importance of professional oversight when using essential oils.

In an effort to demystify its products and put some hard science behind its hard sells, DoTerra in January hired hospital administrator and infectious disease specialist Dr. Russell

Osguthorpe as chief medical officer. He oversees an advisory committee that runs clinical trials in partnership with several universities. “DoTerra sells 100 different essential oils, but there aren’t clinical studies in human beings that tell us how to use them,” he says. “Our goal is to learn what the right doses are and how often you should be taking them—because we don’t even know that basic information.”

If they prove to have placebo effects, Osguthorpe says, DoTerra will leave publication rights up to its partner institutions. “We’re doing research to advance the field, not our business,” he explains.

This would establish a new level of transparency for the brand. Currently the company doesn’t allow the U.S. Department of Agriculture to certify its products as organic. Instead, it operates by its own purity standard. “Basically, we’d have to give away our trade secrets to get certified,” says Kirk Jowers, an executive vice president. “We don’t want our competitors going to our farmers and starting bidding wars.” Until more studies come out, the company is pushing forward

with new products—and its Prime Meridian clinics. The third such practice will soon open; patients will pay \$99 per month for unlimited access to board-certified medical doctors and osteopaths who specialize in preventive, integrative care. “Acupuncture, massage, essential oils—we’ll offer anything that can help treat the patient in a better way,” Osguthorpe says. “But the doctors are not going to be salespeople.” **B**





## INSIDER INGREDIENT

# Hopping to a Menu Near You

*Chapulines*, aka grasshoppers, are the latest Mexican treat to cause a stir in the U.S. *By Kate Krader*  
*Photograph by Danny Kim*

Most Americans don't gravitate toward edible insects unless they're the gummy kind. But 80 percent of the people on Earth consume bugs. And diners in the U.S. are finally coming around to this sustainable source of high-quality protein.

For centuries, grasshoppers, or *chapulines*, have been a Mexican specialty, particularly in the southern state of Oaxaca. They're a staple snack at soccer games and in market stalls in Mexico City, where you'll find baskets piled high with them. Chapulines are cleaned, toasted on a griddle-like surface, and seasoned with ingredients such as lime juice and garlic. They deliver a distinctive earthy flavor and add an addictive crunch to dishes.

Chapulines got a lot of social media play in 2017 when Noma chef René Redzepi served them on a fried corn pastry with dried tomatoes at his pop-up in Tulum, Mexico. Now they can be found at other acclaimed spots, such as Alex Stupak's Empellón restaurants in New York. "The best way to taste them is to put them in a tortilla with a little guacamole and a splash of smoky salsa," Stupak says. "The first time we offered them, I was blown away by how many we sold."

At Michelin-starred Claro in Brooklyn, N.Y., chef T.J. Steele purées them into a vinaigrette. "For some chefs, bugs are

#### CLARO'S CHAPULINE VINAIGRETTE

In a small saucepan, heat ½ cup of vegetable oil. Add ¼ cup finely chopped garlic and cook over low heat until golden and fragrant. Add ¼ cup grasshoppers and cook for 2 minutes; let cool. Thoroughly puree in a blender with 1 tbsp. sherry or cider vinegar, about ½ tsp. sugar, and a large pinch of salt; taste for seasoning. Refrigerate for up to 2 weeks. Makes about ¾ cup.

about shock value," he says. "With grasshoppers, it's about flavor, especially if you grind them up and people don't notice them." Steele's chapuline-drizzled salad also shows up at the Brooklyn Museum's restaurant, the Norm, where it was introduced to complement a Frida Kahlo exhibit.

At the ambitious Sazón in Santa Fe, N.M., chef Fernando Olea serves marinated chapulines on mini corn tortillas. Grasshoppers have even become a hit at the Seattle Mariners' T-Mobile Park. Served in spicy chili powder, they became so popular that a limit on sales had to be imposed in 2017; now they garnish the Buzz margarita.

One of the suppliers to the Seattle stadium is the Maine-based Entosense LLC, which Bill Broadbent and his sister, Susan, founded in 2015.

"When we started, we had two employees and sold 1 ounce at a time," he says. "Now we have six employees, and we sell bugs by the pound. By the end of the year, our chapuline business will have gone up 20 to 30 times what we did last year." Broadbent notes that when his daughter brings them to school, her friends pounce. "People under 40, there's a good chance they'll eat bugs," he says. "For people over 40, it's tougher." **B**

# Big Is Beautiful

Maximize comfort with a puffy armchair that's large and in charge. *By Monica Khemsurov*  
*Photographs by Sarah Anne Ward*

These bulbous armrests are inspired by the hot-air balloon invented by the Montgolfiere brothers, after whom the chair is named

## PUFFER CHAIR

Dimensions: 39"w x 36"d x 27"h

Moving Mountains, a studio in Brooklyn, N.Y., combined 1970s Italian and California design to create this vision of laid-back living. The beanbag-like seat sits on a swiveling base, so the whole thing seems to hover barely above ground; it's available in your choice of materials and finishes. \$5,500; [goodcolony.com](http://goodcolony.com)

72

## MONTGOLFIERE ARMCHAIR

Dimensions: 44.1"w x 43.3"d x 29.5"h  
As part of the Globe Trotter collection for French furniture brand Roche Bobois, this design—from the exuberant mind of Marcel Wanders—looks light and fluffy but is solidly constructed from pine, fir, and metal. And if this red fabric is too tame for you, there are bolder options. It can also be configured as a sofa or an ottoman. \$5,100; [roche-bobois.com](http://roche-bobois.com)

Coil springs, painstakingly hand-tied, provide cushy support

**MOLLO ARMCHAIR***Dimensions: 68.1"w x 46.5"d x 26.8"h*

For the London studio Established & Sons, designer Philippe Malouin created this instantly recognizable, exceptionally comfortable throne entirely out of a high-density polyurethane foam. It sits on the floor, but your seat remains more than 17 inches off the ground.

*\$14,646; mattermatters.com*

**CAPE LOUNGE CHAIR***Dimensions: 33"w x 37"d x 31.5"h*

Danish designer Charlotte Honcke's Cape lounge chair, produced in collaboration with the Scandinavian furniture brand Warm Nordic, is inspired by the puffed sleeves and layered designs of haute couture. It comes in seven colors and a range of high-quality fabrics from Kvadrat. *\$2,355; warmnordic.com*

This chair can be customized so its seams are visible

**PACHA LOUNGE CHAIR***Dimensions: 24.4"w x 27.16"d x 27.35"h*

First designed in 1975 by Pierre Paulin, the Pacha was a pioneer in so-called low-level living—a way of sitting on or near the floor by getting rid of chair legs. Produced by the brand Gubi in Copenhagen, it's as contemporary and comfortable as ever. *\$2,759; suiteny.com*



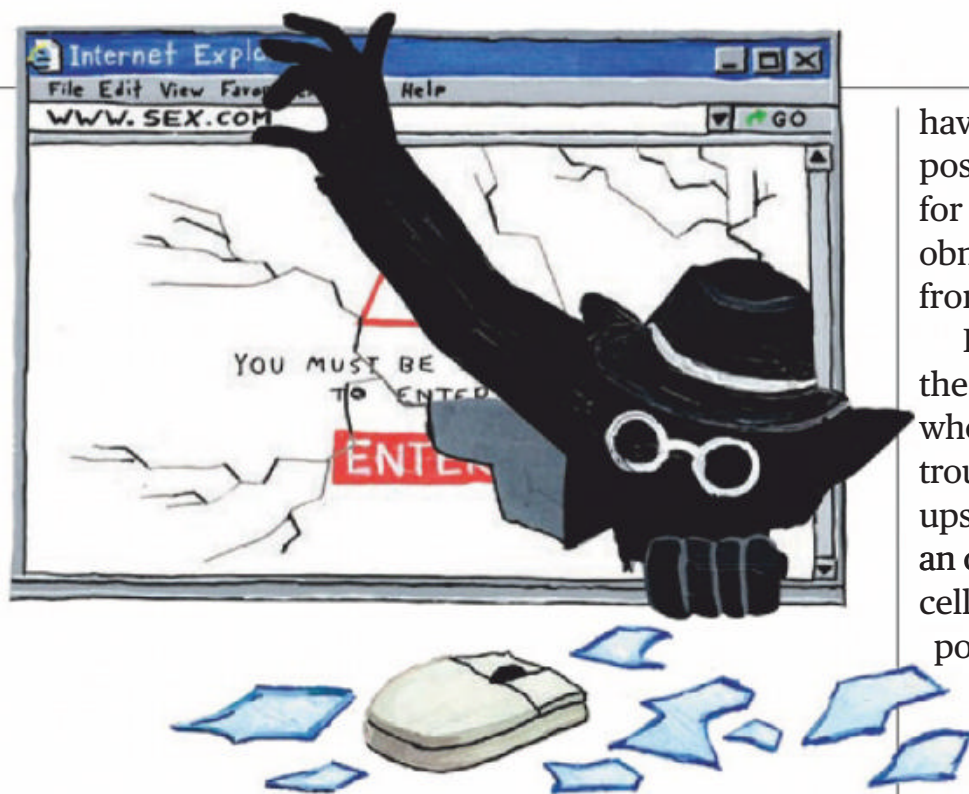

# The Internet's Filthy Roots

The yearslong battle over sex.com was proof that even shady characters could help make good web policy. *By Devin Leonard*

Most of us think of the business leaders behind the modern internet as clean-cut, scientifically minded overachievers, such as Amazon.com's Jeff Bezos, Facebook's Mark Zuckerberg, and Google's Larry Page and Sergey Brin. But as David Kushner writes in *The Players Ball: A Genius, a Con Man, and the Secret History of the Internet's Rise*, their arrival followed a tumultuous period when the web was a Wild West and less refined characters made fortunes by staking claims wherever and however they could.

The so-called genius in *The Players Ball* is Gary Kremen, a Stanford grad who gets his start as a teen selling stolen copies of *Playboy*. He's so badly dressed and unsociable that he's asked to leave his Goldman Sachs summer internship early. He doesn't change much as an adult—living on burritos, attending meetings in dirty T-shirts, and not brushing his teeth.

Yet in the early 1990s, Kremen is shrewd enough to realize that certain domain names will be worth a fortune one day. He scoops up the rights to some of the choicest, including jobs.com, housing.com, autos.com, match.com, and sex.com, the latter of which he one day envisions as a sexual wellness site. He's more than a little prescient: In 1994, Kremen borrows \$2,500 and turns match.com into an internet dating site that would eventually become a multibillion-dollar business.

The site doesn't take off without some finagling. Early on, Kremen goes on a tirade, incensed that match.com doesn't

have any women users. So the company has female interns post laudatory reviews and a woman on staff pose as a user for a *Rolling Stone* spread. When the board tires of Kremen's obnoxious behavior, he quits Match, never pocketing a nickel from his investment.

If Kremen is the closest thing to a hero in *The Players Ball*, the villain is Stephen Michael Cohen, a convicted con artist who passes bad checks, impersonates lawyers, and gets into trouble in the early '90s for running a swingers' club in a quiet upscale Southern California neighborhood. He also operates an online hookup service, the French Connection, from a jail cell. When he can't attract women to the site, he fakes it by posing as a female user named "Tammy."

Cohen strikes virtual gold when he acquires Kremen's sex.com through an elaborate fraud that involves impersonating a vice president of an internet domain registration company. He turns it into a thriving business, with 9 million members paying \$24.99 monthly. Along the way, he helps pioneer many things we now take for granted online, such as banner ads and secure credit card transactions. Cohen may be a crook and a sleaze, but he, too, is something of a visionary.

Having missed out on his match.com millions, Kremen is determined not to endure similar humiliation with sex.com. Kushner devotes much of *The Players Ball* to his protagonist's multiyear, drug-fueled legal crusade to win the site. That's too bad. Like the porn references Kushner copiously sprinkles throughout the book, the lawyerly thrusting and parrying get numbing. Kremen prevails in 2001 when a California judge rules that domain names are, in fact, property and that he's the rightful owner and awards him \$65 million in damages. As his lawyer puts it, "The substantial size of this damage award sends a message that the internet is not a lawless wasteland."

But is the virtual world really tamed? Today's internet business leaders may practice better dental hygiene, but they still prefer to operate as if the web were an unkempt frontier where rules can be ignored. Perhaps the best example is Travis Kalanick, the former Uber Technologies Inc. chief executive officer (and still board member) who, in the rush to dominate the ride-sharing industry, fostered a Darwinian corporate culture that tolerated sexual harassment, alleged theft of intellectual property, and efforts to mislead government authorities.

He's obviously not alone. Until recently, Zuckerberg turned a blind eye to hatemongers exploiting his network to peddle execrable conspiracy theories. Now he's joined political leaders in the U.S. and Europe who call for tighter rules on the internet. It's a recurring theme: Entrepreneurs often cry out for regulation only when it might at last benefit them.

By the end of *The Players Ball*, Kremen and Cohen have moved on to new hustles. Having sold sex.com for \$12 million, Kremen, now a clean-energy advocate, runs for a seat on a water district board in Silicon Valley and uses his fortune to pummel his hapless opponent, an environmental attorney. (Spoiler alert: Kremen wins.) As for Cohen, having recently completed another prison stint, he's salivating over a new internet technology: Bitcoin. **B**

# Air Conditions

Flow is a wearable device that tracks pollution wherever you may roam

*Photograph by Will Anderson*

Thanks to the development of inexpensive sensors, several products claiming to test air quality have hit the market in recent years. Flow (\$179), developed by Paris-based Plume Labs SAS, is a portable pollution sensor that's encased in aluminum punched with a pattern of asymmetric holes for "360 air intake." The device uses a tiny fan to suck in air as a combination of lasers and membranes detects what's in it. An app introduced with the device in September breaks the measurements down into particulate matter (PM), nitrogen dioxide (NO<sub>2</sub>), and volatile organic compounds (VOCs) in real time.



Flow is almost 5 inches long and weighs about 2½ ounces

## THE COMPETITION

- The white-plastic casing of the \$249 Airbeam2, shaped like a cartoon ghost, houses PM, humidity, and temperature sensors and works with an Android-only app. At about 5 by 4 inches, it's designed for on-the-go use but is much larger than other devices.
- Another wearable device, the \$99 Atmotube Plus, is about the size and shape of a lipstick container. It also works with an app to monitor VOCs, along with air pressure, temperature, and

humidity. A more robust model due in May will include a laser for PM measurements.

- Pico (from \$99) measures PM, VOCs, ozone, temperature, humidity, UV, and CO<sub>2</sub>eq—or carbon-dioxide equivalent, a unit for measuring the global-warming potential of different greenhouse gases. That's all in a device less than 2 square inches. The downside: It requires an external power supply such as a smartphone or wall outlet to function. Pico will be available in the U.S. in June.

## THE CASE

Many first-time users of Flow are surprised to realize how polluted the air in their house is, especially if they're cooking without proper ventilation. But the device can be handy in other scenarios, too. As the only consumer product that measures NO<sub>2</sub> emissions that result from combustion and traffic, it detects one of the most widespread pollutants that contribute to asthma and bronchitis. A map crowdsourced from users is color-coded to provide an at-a-glance picture of the air pollution in your area, whether you're planning a bike commute, taking your kids to school, or going for a downtown run while on a business trip. Plume Labs' award-winning system comes with an easy-to-read interface, an air-quality index, and an elegant design that gives you a clearer view of the invisible stuff in the air. \$179; [plumelabs.com](http://plumelabs.com)

# Migration Is Slowing. Yes, Really

By Justin Fox

76

Gallup recently estimated, on the basis of polling in 152 nations, that about 750 million people around the world want to move to another country. That's a lot! North America and Western Europe are the most favored destinations, which will conjure visions for some people of vast waves of immigrants crashing upon their shores.

Saying you want to emigrate and actually doing it are very different things, though. According to Gallup, 16 percent of U.S. residents wish to leave. The U.S. diaspora is something less than 3 percent of the domestic population, so I'm guessing a lot of Americans aren't serious about their stated intentions. In other countries, the will might be there but the way is not. Immigration restrictions play a role, but so do low incomes, as many lack the resources to leave.

As incomes rise in a poor country, emigration does, too. Eventually, though, increased affluence and falling birthrates bring a reversal. In a 2009 paper that documented this "emigration life cycle," economists Timothy Hatton and Jeffrey Williamson found that emigration from Asia and Latin America was already slowing, and that while it was on the upswing in sub-Saharan Africa, overall emigration from developing countries was likely to decline in coming decades. United Nations data in fact show a modest global migration slowdown since 2010.

Climate change and political turmoil might create new pressures on people to move, and much depends on the future trajectories of incomes and still-high birthrates in Africa. Still, far from facing a vast new global migration wave, we may be witnessing the beginning of the end of one.

● —Fox is a business columnist for Bloomberg Opinion



● **THE BABY QUESTION**  
At a fertility rate of 2.1 births per woman, population stops growing. The global fertility rate was 2.4 and falling in 2016, according to the World Bank, but the decline isn't uniform. In sub-Saharan Africa the fertility rate was 4.8, meaning there's lots of population increase still to come there.

● **TICKET TO RIDE**  
Emigration tends to peak at a per capita gross domestic product of

**\$8k**

to \$10,000. Every world region except sub-Saharan Africa is now at or near that threshold.

● **GIMME SHELTER**  
Civil war in Syria has unleashed a recent refugee surge, but before that, UN estimates of refugee numbers were falling. Refugees' share of world population remains lower than in 1990.

● **Average annual increase in the global migrant population**

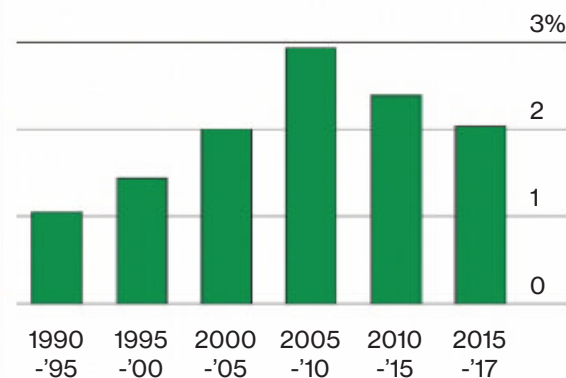

● **COMING TO AMERICA**  
Of the Central American countries now sending lots of immigrants to the U.S., Guatemala has a purchasing-power adjusted per capita GDP of \$8,150, El Salvador \$8,006, and Honduras \$4,986.



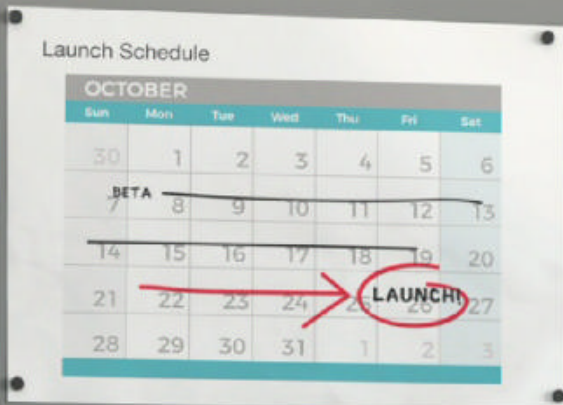
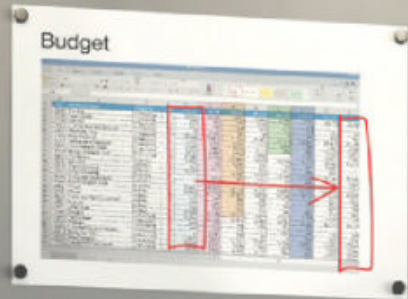

Objectives

- Business goals
- High-level requirements
- Project specific??
- Measuring/analyzing success?

Notes on User Research

- High-level design
- Define user behavior and illustrate!

Beta Launch

- App store testing
- Support + maintenance
- Roll out planning

2 MONTH PHASE

MULTIFACETED APP... 600-700 users

Remember our mission!

Decide WHICH UPS is needed by development team

INFORMATION ARCHITECTURE ELEMENT

PR - Launch party

Customization of user experience

Data integration

3rd party service?

PM - NOTIFICATION SERVICES

Checklist

2 million apps in Google Play

2 million apps in App Store

Single | Complex

3-4% | 10-15%

Content covered with user available

Audience

- Restaurant food delivery 5x/month
- Online dinner reservations 3x/month
- Meal kit delivery 50%

Market results?

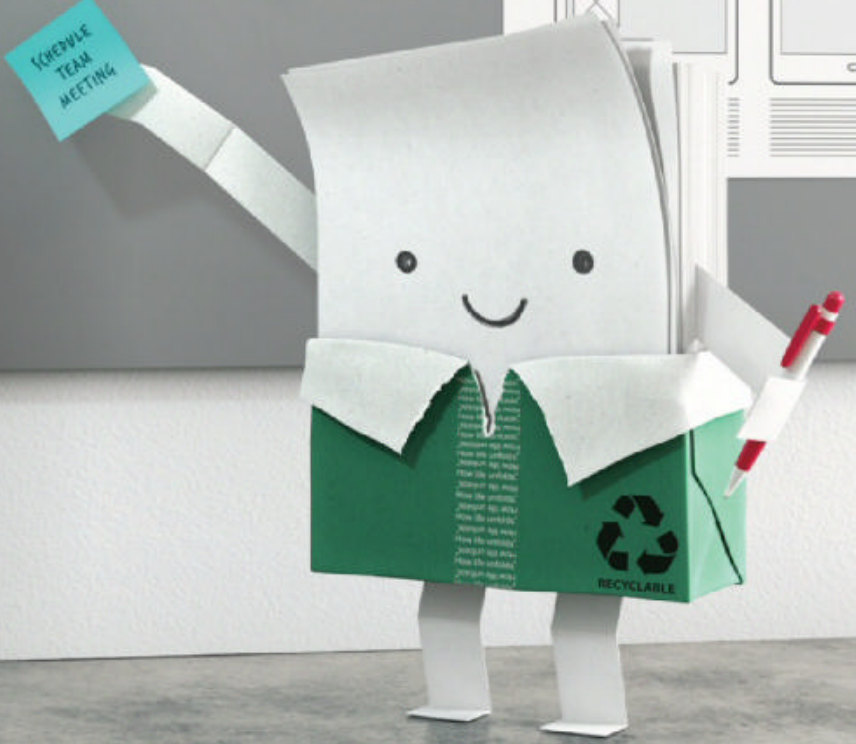

# Paper shows you mean business.

Collaboration. Ideation. Innovation. From concept to completion, paper is at the center of it all. It encourages fresh ideas, motivates decisions and helps teams work toward one shared goal. When getting the job done matters, use paper. Learn more at [howlifeunfolds.com/productivity](http://howlifeunfolds.com/productivity).

